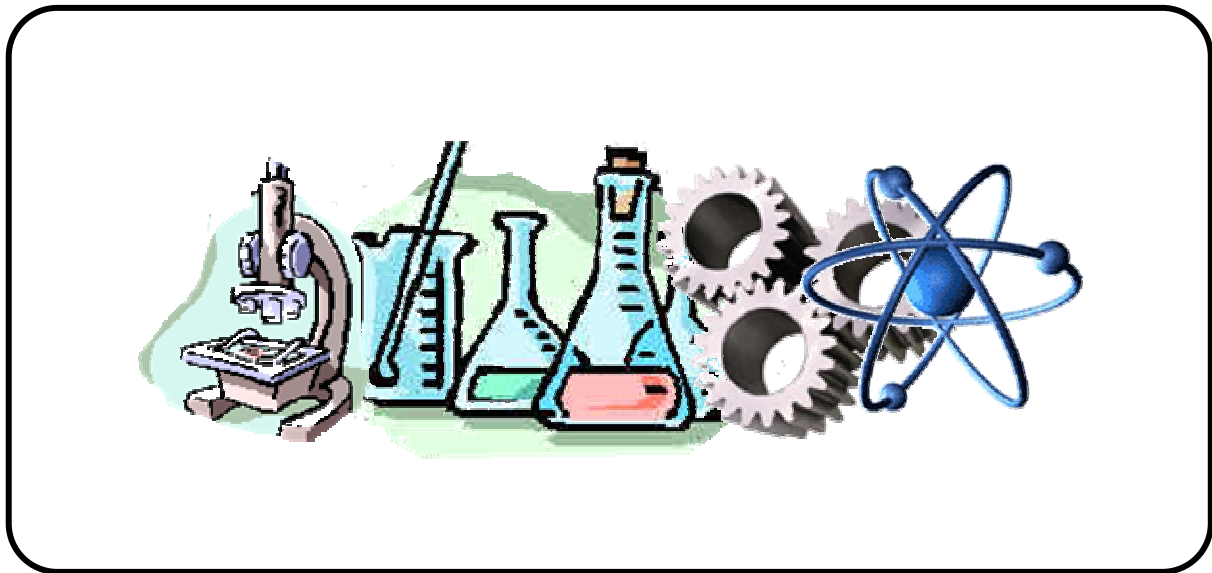


# Project EASE

(Effective and Alternative Secondary Education)

## INTEGRATED SCIENCE I



### MODULE 4



**BUREAU OF SECONDARY EDUCATION**

Department of Education  
DepED Complex, Meralco Avenue  
Pasig City



# Module 4

## *Safety in the Laboratory*

The third module provided activities aimed at honing your skills as a budding scientist. This time, your manner of solving a particular problem will be enhanced because you will now become a chemist working in a laboratory with different apparatus on hand. Just read and follow the instructions in this module. Good luck and have fun!



### *What this module is about*

The activities in this module will teach you how to use different apparatus in the laboratory. This will also enhance your skills in making accurate measurements using common laboratory equipment and using the equipment properly.

This module contains the following lessons:

- **Lesson 1 - Common Laboratory Apparatus and their Uses**
- **Lesson 2 - Laboratory Safety Precautions**
- **Lesson 3 - Laboratory Safety Symbols**



### *What you are expected to learn*

You will now work as a scientist / chemist as you go along this module.

After going through this module, you are expected to:

1. identify and classify different laboratory apparatus based on their uses;
2. use each laboratory apparatus accurately and properly;
3. discuss different precautionary measures in the laboratory; and
4. recognize different signs and symbols in the laboratory and know their significance.



## *How to learn from this module*

Here's a simple guide for you in going about the module:



1. Take your time in reading the instructions.
2. Know the meaning of the different words used in this module:
  - a. ACID – a substance which can burn the skin and other materials
  - b. BREAKABLE – characteristic of materials that easily break like glass when dropped or subjected to pressure
  - c. CERAMICS – a kind of material that is made of porcelain
  - d. EVAPORATION – process of changing liquid to gas
  - e. FLAMMABLE – the ability of a material to burn
  - f. GLASSWARES – materials that are made of glass like test tubes and beakers
  - g. REAGENT – a kind of chemical used in the laboratory
  - h. VOLATILE – the ability to evaporate easily
  - i. VOLUME – amount of space occupied by matter
  - j. TOXIC – poisonous substance
  - k. RADIOACTIVE – a substance that is not stable and decays spontaneously
  - l. FUME – a gaseous substance that is emitted by chemicals
  - m. CORROSIVE – acids and bases that can react with and destroy tissue and other materials
3. Follow the instructions very carefully.
4. Before working on the activities, answer the 10-item test honestly in order to determine how much you know the topics in this module.
5. Check your answers against the given answer key.
6. Perform all the activities diligently as these will help you understand the lessons.
7. Take the self-tests after each lesson.
8. At the end of the module, take the post-test to measure how much you understood the lesson.

**Good Luck!**



## *What to do before (Pretest)*

Direction: Encircle the letter of the best answer.

- Suppose you saw your mother accidentally cut her finger with a broken glass at home? What will you do?
  - Call a doctor right away
  - Call your neighbors for help.
  - Ignore her and proceed with your playing.
  - Get a medicated plaster and put it around her finger as first aid.
- While doing an experiment, you happen to come across a bottle with the sign "SKULL" pasted on it. What does the sign tell you about the content of the bottle?
  - Its content is edible.
  - Its content is volatile.
  - It contains a dead insect.
  - The chemical inside is poisonous.
- Given three laboratory apparatuses: beaker, graduated cylinder and test tube. Which will you use to get the volume of water?
  - beaker
  - test tube
  - graduated cylinder
  - any of the three
- Your teacher asks you to get the mass of a piece of stone. What apparatus will you use?
  - graduated cylinder
  - triple beam balance
  - Florence flask
  - Erlenmeyer flask
- What does this mean?
  - It is poisonous
  - It is radioactive
  - It is a metal
  - It is a non-metal
- You are asked to boil about 10 mL of water using a test tube. What is the proper way of holding the test tube when you're working with somebody in a laboratory?
  - Let the test tube face your partner while it is being heated.
  - Keep the test tube away from anybody else inside the laboratory.

- c. Hold the test tube directly above the flame.
  - d. All of the above
7. Which of the following is NOT in the group of apparatus that are used in storing liquids?
- a. Reagent bottle
  - b. Beaker
  - c. Florence flask
  - d. graduated cylinder
8. Which of these apparatus will you use if you want to measure the density of a certain liquid?
- a. beaker and test tube
  - b. graduated cylinder and triple beam balance
  - c. test tube and platform balance
  - d. beaker and graduated cylinder
9. What will you use to fill a small-mouthed bottle with liquid without spilling?
- a. a test tube
  - b. a funnel
  - c. a petri dish
  - d. a graduated cylinder
10. When doing an experiment that uses fire, what should you be ready with?
- a. an apron
  - b. a damp cloth
  - c. a pail of water
  - d. a wet tissue paper



Key to answers on page 24

## Lesson 1 Common Laboratory Apparatus and their Uses

When you think of scientist at work, you probably imagine them in a modern laboratory with test tubes, other delicate instruments, apparatus, and bottles of strange substances.

You're right. In the laboratory, you can find several laboratory apparatus. Perhaps you are already familiar with some of them through your readings, or from watching television or the movies or perhaps you have actually used them in your elementary science.

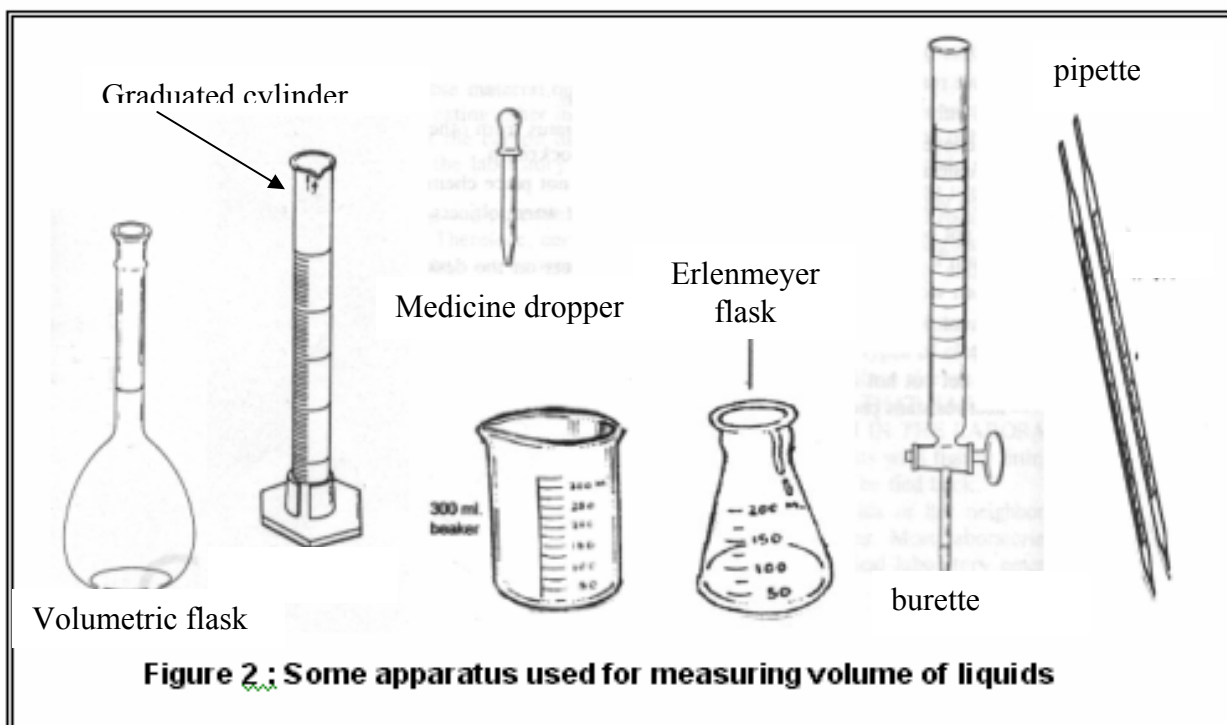
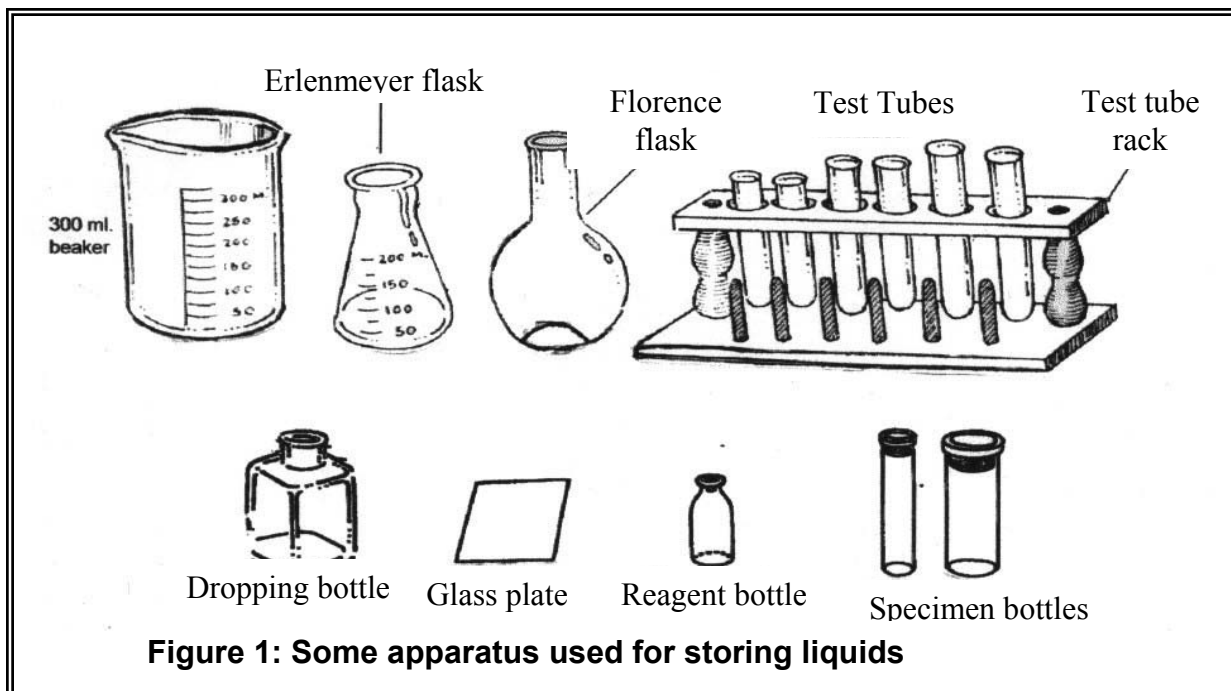
Let us familiarize ourselves with the different laboratory apparatus and their uses.

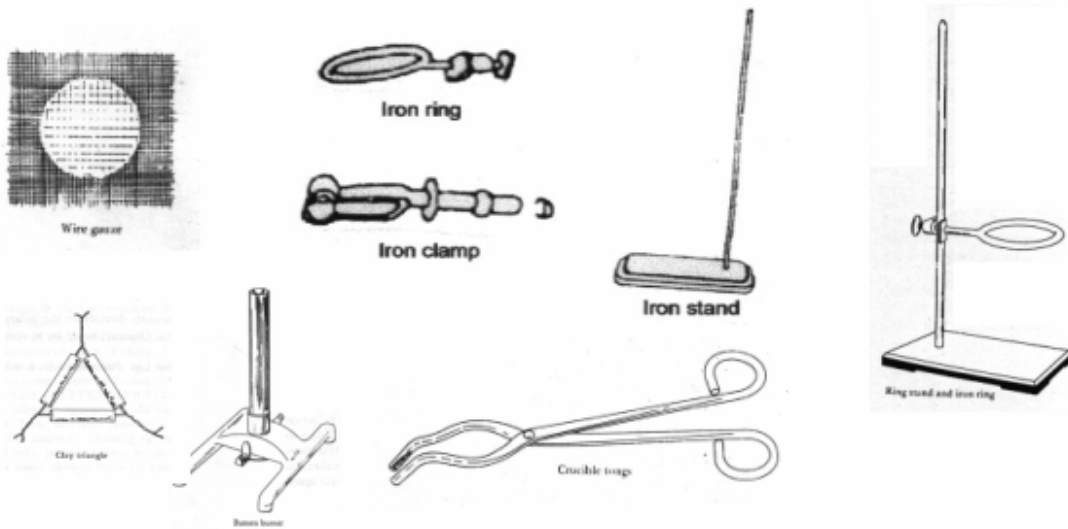


## *What you will do*

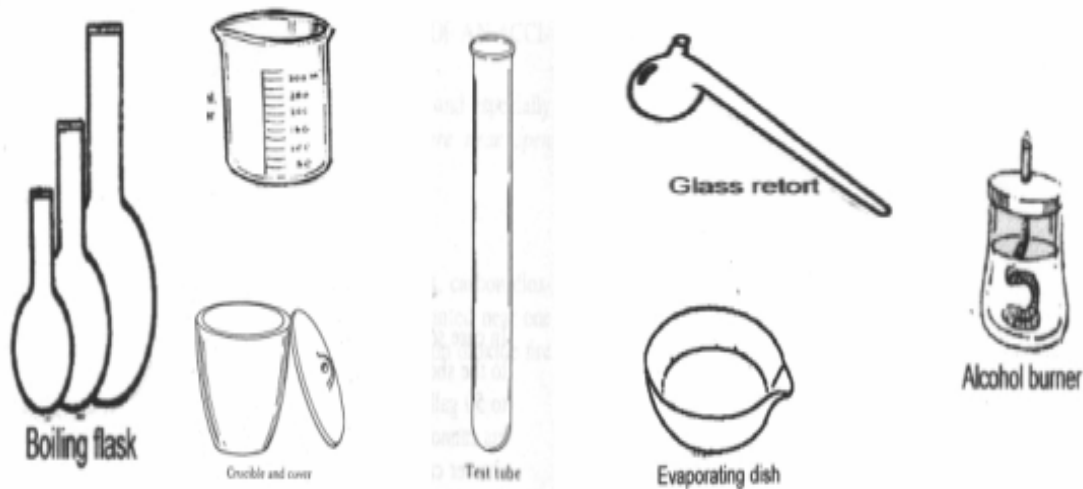
### Activity 1.1 Some Common Laboratory apparatus and their uses

Study the different apparatus grouped in each box.

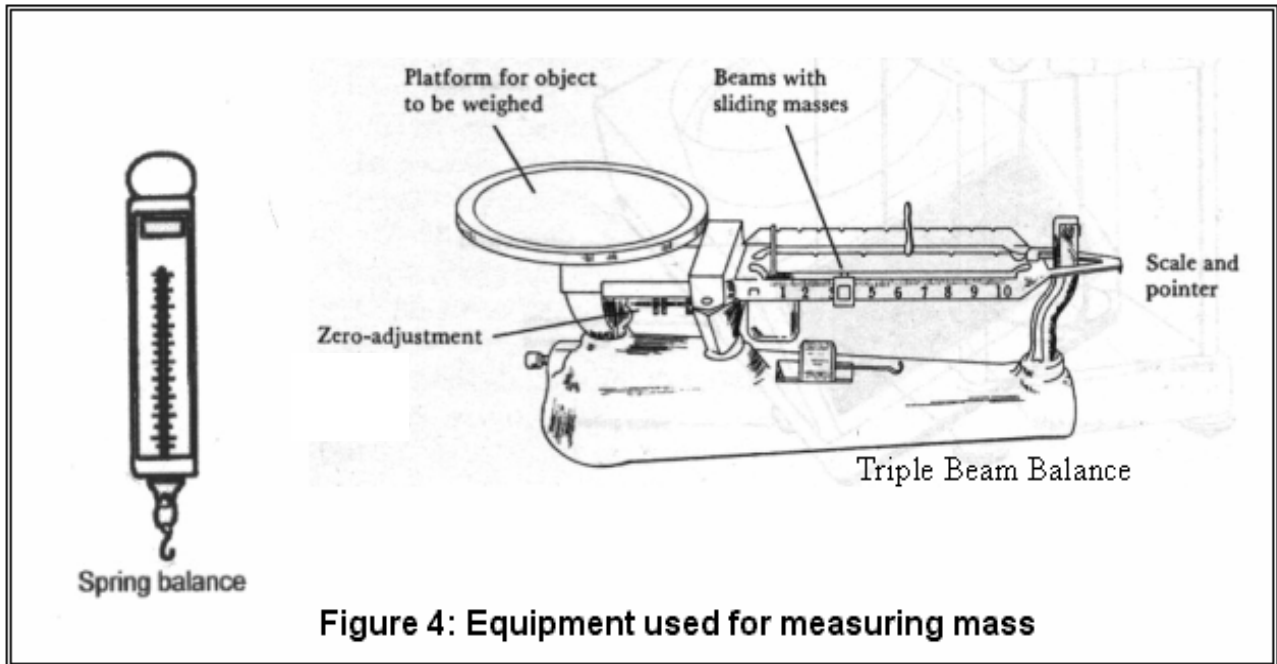




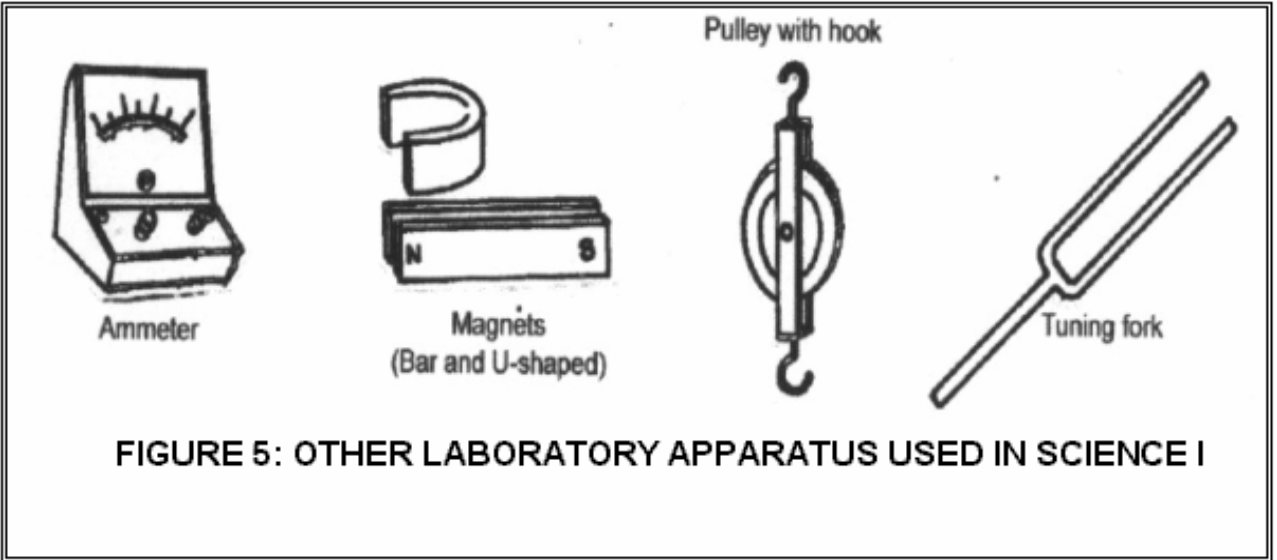
**Figure 3.1: Apparatus (Metals) used when heating substances**



**Figure 3.2: Apparatus (Glassware) used when heating substances**

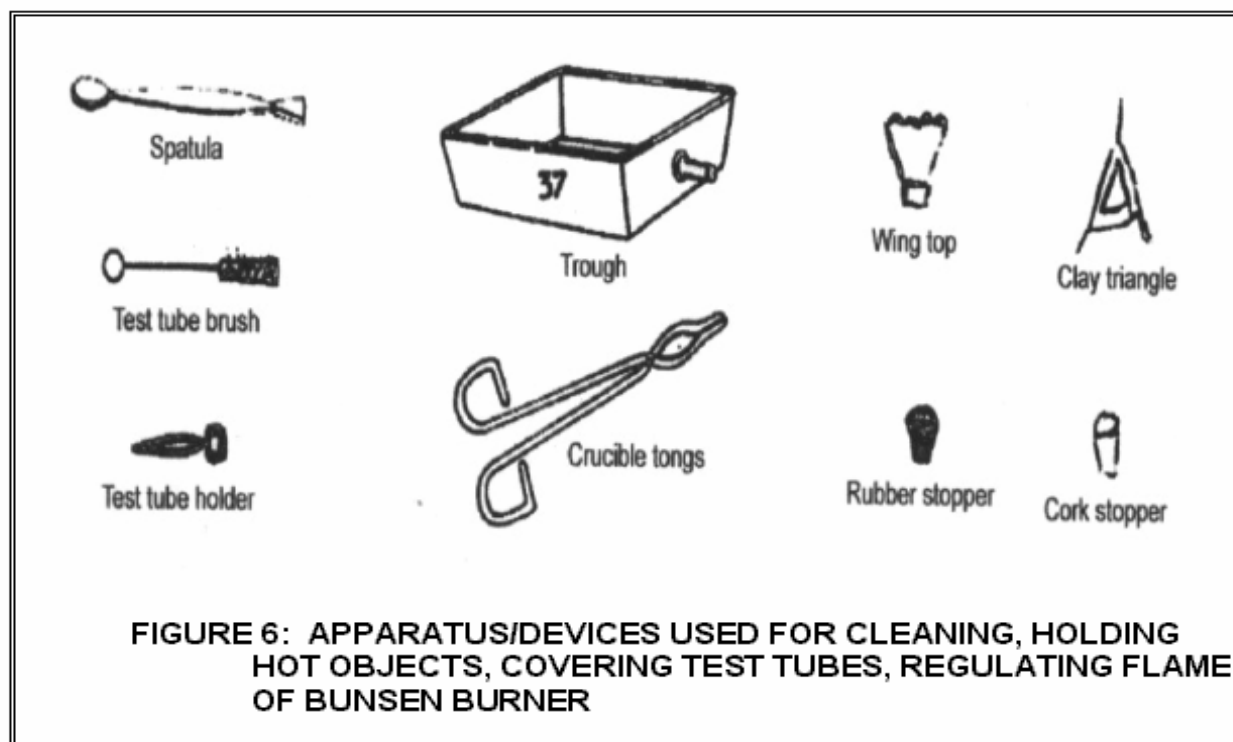


**Figure 4: Equipment used for measuring mass**



**FIGURE 5: OTHER LABORATORY APPARATUS USED IN SCIENCE I**





 *What you will do*  
Self-Test 1.1

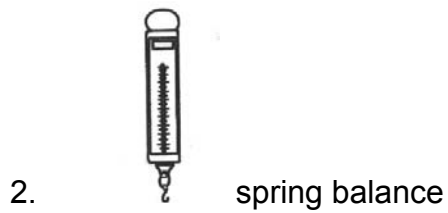
Matching Type: Shown in Column A are the drawings of some common laboratory apparatus listed. In Column B are the uses of these apparatus. Draw a line that connects each apparatus with its use.

**COLUMN A  
APPARATUS**

**COLUMN B  
USES**

1.  beaker

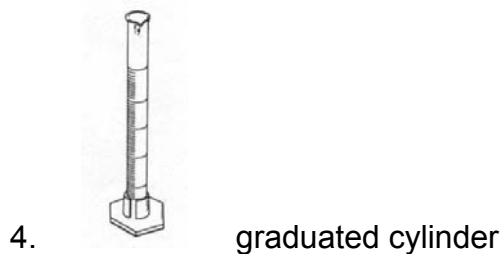
- A. used to transfer small amount of liquid from the reagent bottle to a test tube



B. used to clean test tubes or glassware with narrow opening



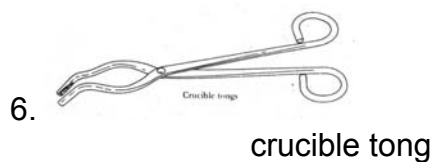
C. used to measure the volume of liquid



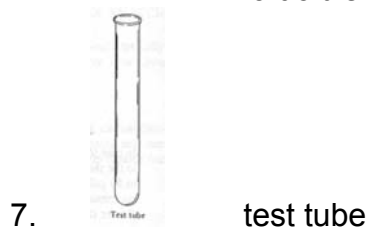
D. used in evaporating the liquid substances when heating



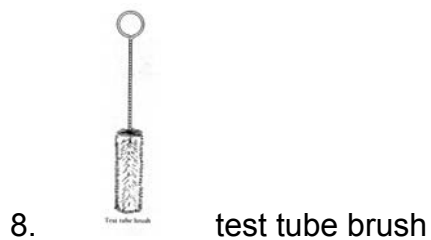
E. used to measure the mass of an object



F. used to hold liquid / solution to be tested



G. used to hold hot materials



H. used to pulverize solid materials to make it in powder form



I. used to contain liquids or solution in large amount



10. medicine dropper

J. used for heating substances



Key to answers on page 24

## Lesson 2 Laboratory Safety Precautions

Science is a hands-on laboratory class. You will be doing many laboratory activities that require the use of different apparatus and hazardous chemicals. Safety in the science classroom is the number one priority for students and teachers. To ensure a safe science classroom, a list of rules has been developed and provided for you in this module. These rules must be followed at all times. The science laboratory is a safe place to work in if you are careful.



### *What you will do*

#### Activity 1.2

Following are some safety precautions and procedural rules to help you protect yourself from injury in the laboratory while doing the experiment. Read and understand them to insure your safety before, during and after doing an experiment.

#### **A. Inside the Laboratory:**

1. Do not eat food, drink beverages, or chew gum in the laboratory. Do not use laboratory glassware as containers for food or beverages.
2. Safety goggles and aprons must be worn whenever you work in the lab. Gloves should be worn whenever you use chemicals that cause skin irritations or when you need to handle hot equipment.
3. Observe good housekeeping practices. Work areas should be kept clean and tidy at all times.

4. Know the locations and operating procedures of all safety equipment including the first aid kit, eyewash station, safety shower, spill kit, fire extinguisher, and fire blanket. Know where the fire alarm and the exits are located.
5. Be alert and proceed with caution at all times in the laboratory. Notify the instructor immediately of any unsafe conditions you observe.
6. Dispose all chemical waste properly. Never mix chemicals in sink drains. Sinks are to be used only for water and those solutions designated by the instructor. Solid chemicals, metals, matches, filter paper, and all other insoluble materials are to be disposed of in the proper waste containers, not in the sink. Check the label of all waste containers twice before adding your chemical waste to the container. Cracked or broken glass should be placed in the special container for "Broken Glass."
7. Labels and equipment instructions must be read carefully before use.
8. Know what to do if there is a fire drill during a laboratory period; containers must be closed, gas valves turned off, fume hoods turned off, and any electrical equipment turned off.
9. Keep hands away from your face, eyes, mouth, and body while using chemicals. Wash your hands with soap and water after performing all experiments. Clean (with detergent powder), rinse, and dry all work surfaces and equipment at the end of the experiment.
10. If you spill acid or any other corrosive chemical on you skin or clothes immediately wash the area with large amounts of water (remember that small amounts of water may be worse than no water at all). After this get the teacher's attention. The spill kit will be used for spills on floor or counter-top.
11. At the end of the laboratory session see that: a) the main gas outlet valve is shut off b) the water is turned off c) the desk top, floor area, and sink are clean d) all equipment are cool, clean, and arranged properly.

## **B. Clothing**

1. Any time chemicals, heat, or glassware are used, students will wear laboratory goggles.
2. Dress properly during a laboratory activity. Long hair, dangling jewelry, and loose or baggy clothing are a hazard in the laboratory. Long hair must be tied back and dangling jewelry and loose or baggy clothing must be secured. Shoes must completely cover the foot. No sandals are allowed.

## **C. Accidents and Injuries**

1. Report any accident (spill, breakage, etc.) or injury (cut, burn, etc.) to your teacher.

2. If a chemical should splash in your eye(s), immediately flush with running water from the eyewash station for at least 20 minutes. Notify your teacher immediately.

#### **D. Handling Chemicals**

1. All chemicals in the laboratory are to be considered dangerous. Do not touch, taste, or smell any chemical unless specifically instructed to do so. The proper technique for smelling chemical fumes is to gently fan the air above the chemical toward your face. Breathe normally.
2. Check the label on chemical bottles twice before removing any of the contents. Take only as much chemical as you need. Smaller amounts often work better than larger amounts. Label all containers and massing papers holding dry chemicals.
3. **Never return unused chemicals to their original containers.**
4. Acids must be handled with extreme care. **ALWAYS ADD ACID SLOWLY TO WATER**, with slow stirring and swirling, being careful of the heat produced, particularly with sulfuric acid.
5. Handle flammable hazardous liquids over a pan to contain spills. Never dispense flammable liquids anywhere near an open flame or source of heat.
6. Take great care when transferring acids and other chemicals from one part of the laboratory to another. Hold them securely and in the method demonstrated by the teacher as you walk.

#### **E. Handling Glassware and Equipment**

1. Inserting and removing glass tubing from rubber stoppers can be dangerous. Always lubricate glassware (tubing, thistle tubes, thermometers, etc.) before attempting to insert it in a stopper. Always protect your hands with towels or cotton gloves when inserting glass tubing into, or removing it from, a rubber stopper. If a piece of glassware becomes "frozen" in a stopper, take it to your instructor for removal.
2. When removing an electrical plug from its socket, grasp the plug, not the electrical cord. Hands must be completely dry before touching an electrical switch, plug, or outlet.
3. Examine glassware before each use. Never use chipped or cracked glassware. Never use dirty glassware. **Do not immerse hot glassware in cold water; it may shatter.**
4. Report damaged electrical equipment immediately. Look for things such as frayed cords, exposed wires, and loose connections. Do not use damaged electrical equipment.

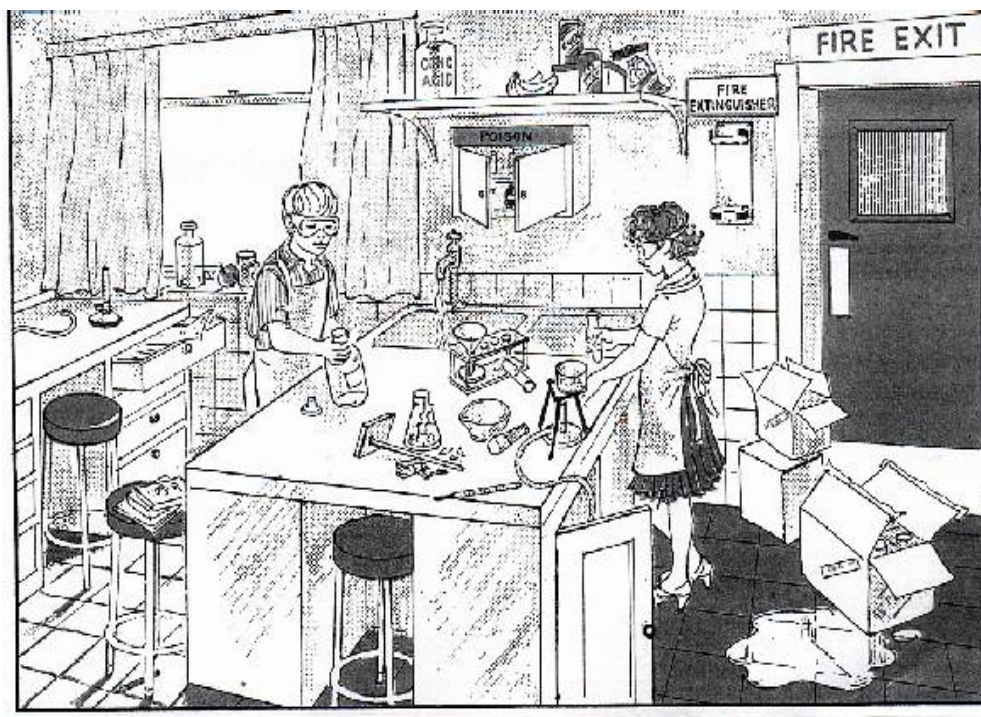
## F. Heating Substances

1. **SHOULD THE BUNSEN BURNER GO OUT, IMMEDIATELY TURN OFF THE GAS AT THE GAS OUTLET VALVE.** If you wish to turn off the burner, do so by turning off the gas at the gas outlet valve first, then close the needle valve and barrel. Never reach over an exposed flame. Light gas burners only as instructed by the teacher.
2. Never leave a lit burner unattended. Never leave anything that is being heated or is visibly reacting unattended. Always turn the burner or hot plate off when not in use.
3. You will be instructed in the proper method of heating and boiling liquids in test tubes. Do not point the open end of a test tube being heated at yourself or anyone else.
4. Heated metals, glass, and ceramics remain very hot for a long time. **They should be set aside to cool on a trivet** and then picked up with caution. Use tongs or heat-protective gloves if necessary. Determine if an object is hot by bringing the back of your hand close to it prior to grasping it.



### *What you will do* Activity 2.1

Look at the scene below. Study and list all the likely causes of accidents.



---

---

---

---

---

---

---

---



Key to answers on page 24

### Activity 2.2

Daria is heating some cupric sulfate solution. List the possible dangers in this scene.



---

---

---

---

---

---

---

---



Key to answers on page 24

### Activity 2.3

Look at the picture. Write down 3 safety rules that this student should follow.



---


---

---

---

---

---

 Key to answers on page 25





## *What you will do*

### Self-Test 2.1

Write **YES** if the statement is a good safety rule in the laboratory and **NO**, if it is not.



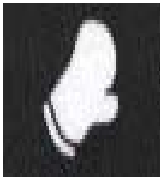

1. Use protective equipment such as gloves, goggles and aprons. \_\_\_\_\_
2. Use plastic containers for hot materials even if these are not heat resistant.  
\_\_\_\_\_
3. When heating liquid substances in a test tube, hold it in a slanting position, away from your body and everyone in the laboratory room. \_\_\_\_\_
5. Taste substances in the laboratory room even if you are NOT told to do so.  
\_\_\_\_\_
5. Be extra careful when working with open flames. \_\_\_\_\_
6. Report any untoward incident to the teacher, no matter how small. \_\_\_\_\_
7. When removing an electrical plug from its socket, grasp the electrical cord. \_\_\_\_\_
8. In diluting an acid ALWAYS ADD ACID SLOWLY TO WATER. \_\_\_\_\_
9. Always bring your food and drinks in the laboratory. \_\_\_\_\_
10. When inside the laboratory, NEVER start an experiment unless you are told to do so. \_\_\_\_\_









Key to answers on page 25

## Lesson 3 Laboratory Safety Symbols

Before beginning your work in the laboratory, you must become familiar with the safety symbols used. The idea of using symbols is to transmit information regarding your safety inside the laboratory clearly and easily. The safety symbols that will be presented in this module are the most familiar ones. These symbols are accompanied by explanations.

SAFETY	SYMBOLS	HAZARD	EXAMPLES	PRECAUTION
DISPOSAL		Special disposal considerations required	Chemicals, broken glass, living organisms such as bacterial cultures, protests, etc.	Dispose of wastes as directed by your teacher
BIOLOGICAL		Organisms or organic materials that can harm humans	Bacteria, fungus, blood, raw organs, plant material	Avoid skin contact with organisms or material. Wear dust mask or gloves, Wash hands thoroughly
EXTREME TEMPERATURE		Objects that can burn skin by being too cold or too hot	Boiling liquids, hot plates, liquid nitrogen, dry ice, all burners	Use proper protection when handling. Remove flammables from the area around open flames or spark sources
SHARP OBJECT		Use of tools or glassware that can easily puncture or slice skin	Razor blade, scalpel, awl, nails, push pins, etc.	Practice common sense behavior and follow guidelines for use of the tool

<b>FUME</b>		Potential danger to olfactory tract from fumes	Ammonia, heating sulfur, moth balls, nail polish remover, acetone, any volatile substances	Make sure there is good ventilation and never smell fumes directly
<b>ELECTRICAL</b>		Possible danger from electrical shock or burn	Improper grounding, liquid spills, short circuits	Double-check setup with instructor. Check condition of wires and apparatus
<b>CORROSIVE</b>		Substances (acids and bases) that can react with and destroy tissue and other materials	Acid such as vinegar, hydrochloric acid, hydrogen peroxide, sodium hydroxide, soap	Wear goggles and an apron
<b>TOXIC</b>		Poisonous substances that can be acquired through skin absorption, inhalation, or ingestion	Mercury, many metal compounds, iodine, poinsettia leaves	Follow your teacher instructions. Always wash hands thoroughly after use
<b>RADIOACTIVE</b>		Radioactive substances such as uranium and plutonium	Uranium, thorium, plutonium and other elements that emit radiation	Be careful in handling. Notify your teacher of spills or excess substances
<b>FLAMMABLE</b>		Combustible materials that may ignite if exposed to an open flame or spark	Alcohol, powders, kerosene, potassium permanganate	Avoid heat and flame sources. Be aware of locations of fire safety equipment

HYGIENE			Always wash your hands after completing an experiment.
---------	---	--	--



*What you will do*  
Self-Test 3.1

On the space provided, write the meaning of the symbols.



1. \_\_\_\_\_



2. \_\_\_\_\_



3. \_\_\_\_\_



4. \_\_\_\_\_



5. \_\_\_\_\_



6. \_\_\_\_\_



7. \_\_\_\_\_



8. \_\_\_\_\_



9. \_\_\_\_\_



10. \_\_\_\_\_



Key to answers on page 25



*Let's summarize*

## A. Laboratory Precautions

### Inside the Laboratory:

1. Do not eat food, drink beverages, or chew gum in the laboratory. Do not use laboratory glassware as containers for food or beverages.
2. Wear safety goggles and aprons
3. Always keep the working area clean and orderly.
4. Know the locations and operating procedures of all safety equipment.
5. Be alert and proceed with caution at all times in the laboratory. Notify the instructor immediately of any unsafe conditions you observe.

### Handling Chemicals

1. All chemicals in the laboratory are to be considered dangerous. Do not touch, taste, or smell any chemical unless specifically instructed to do so.
2. Check the label on chemical bottles twice before removing any of the contents.
3. Never return unused chemicals to their original containers.
4. Acids must be handled with extreme care. ALWAYS ADD ACID SLOWLY TO WATER.
5. Handle flammable hazardous liquids over a pan to contain spills. Never dispense flammable liquids anywhere near an open flame or source of heat.






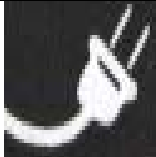
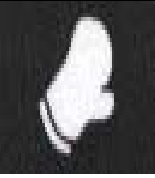
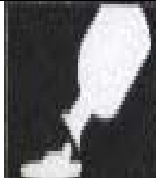




## Handling Glassware and Equipment

1. Always lubricate glassware (tubing, thistle tubes, thermometers, etc.) before attempting to insert it in a stopper.
2. When removing an electrical plug from its socket, grasp the plug, not the electrical cord. Keep your hands dry when working with electricity.
3. Do not immerse hot glassware in cold water; it may shatter.
4. Report damaged electrical equipment immediately.



## Heating Substances

1. TURN OFF THE GAS AT THE GAS OUTLET VALVE after using.
2. Never leave a lit burner unattended. Never leave anything that is being heated or is visibly reacting unattended.
3. Use tongs or heat-protective gloves when holding or touching heated apparatus.

## B. Warning Signs

DISPOSAL		FUME	
		HYGIENE	
BIOLOGICAL		ELECTRICAL	
EXTREME TEMPERATURE		CORROSIVE	
SHARP OBJECT		TOXIC	
FLAMMABLE		RADIOACTIVE	

## Posttest

1. When doing an experiment like heating or anything that uses fire, what should you be ready with?
  - a. an apron
  - b. a damp cloth
  - c. a pail of water
  - d. a wet tissue paper
2. Acids must be handled with extreme care. In diluting an acid, what should you do?
  - a. Do it in anyway you want.
  - b. Always add acid slowly to water
  - c. Always add the water to the acid.
  - d. Mix the acid to the water by stirring
3. Given four laboratory apparatus: spring balance, graduated cylinder, microscope and test tube. Which will you use to get the mass of water?
  - a. the spring balance
  - b. the graduated cylinder
  - c. the test tube
  - d. the microscope
4. *You are asked by your teacher to clean the test tube. What should you use?*
  - a. graduated cylinder
  - b. triple beam balance
  - c. test tube brush
  - d. crucible tong
5. You have come across this icon pasted on a bottle. What does this mean?
  - a. It is poisonous
  - b. It is radioactive
  - c. It is a metal
  - d. It is a non-metal
6. *While inside the hospital's laboratory area, you saw this icon in one of the rooms. What does this mean?*
  - a. The room is strictly for nurses.
  - b. The room is only for technician.
  - c. The room is used for X-ray purposes.
  - d. The room is used for storage of hazardous chemicals.
7. You are asked to measure the density of liquid. Density is defined as mass over volume. Which of the following apparatus will you use?
  - I. beaker
  - II. graduated cylinder
  - III triple beam balance
  - IV. test tube

- a. I and II only
- b. II and III only
- c. III and IV only
- d. I, II, III, and IV

8. Which of the following laboratory precautions is INCORRECT?
- a. All chemicals in the laboratory are to be considered dangerous. Touch, taste, or smell any chemical unless specifically instructed to do so.
  - b. Never leave a lit burner unattended. Never leave anything that is being heated or is visibly reacting unattended.
  - c. Wear safety goggles and aprons at all times in the laboratory.
  - d. Report damaged equipment / apparatus immediately.
9. What will you use to transfer liquid to another bottle without spilling?
- a. a funnel
  - b. a test tube
  - c. a petri dish
  - d. a graduated cylinder
10. Which of the following apparatus does NOT belong to the group?
- a. volumetric flask
  - b. reagent bottles
  - c. test tube
  - d. beaker



Key to answers on page 25





## Key to Answers

### Pretest

- |             |             |             |             |              |
|-------------|-------------|-------------|-------------|--------------|
| 1. <b>b</b> | 2. <b>d</b> | 3. <b>b</b> | 4. <b>b</b> | 5. <b>b</b>  |
| 6. <b>b</b> | 7. <b>d</b> | 8. <b>b</b> | 9. <b>b</b> | 10. <b>b</b> |

### Self-Test 1.1

- |             |             |             |             |              |
|-------------|-------------|-------------|-------------|--------------|
| 1. <b>I</b> | 2. <b>E</b> | 3. <b>J</b> | 4. <b>C</b> | 5. <b>D</b>  |
| 6. <b>G</b> | 7. <b>F</b> | 8. <b>B</b> | 9. <b>H</b> | 10. <b>A</b> |

### Self-Test 2.1

- |               |              |               |              |                |
|---------------|--------------|---------------|--------------|----------------|
| 1. <b>YES</b> | 2. <b>NO</b> | 3. <b>YES</b> | 4. <b>NO</b> | 5. <b>YES</b>  |
| 6. <b>YES</b> | 7. <b>NO</b> | 8. <b>YES</b> | 9. <b>NO</b> | 10. <b>YES</b> |

### Possible Answers for Activity 2.1

1. Pieces of paper are scattered on the floor.
2. The tripod with the beaker on it is not set properly.
3. Several apparatus not needed in the experiment are on top of the table.
4. Laboratory area is untidy and disorderly.
5. The test tube is not placed properly on the rack.
6. There is no fire extinguisher installed.
7. Chemicals are not properly labeled.
8. Chemicals are placed anywhere.
9. Laboratory area is topsy-turvy.
10. There are hanging curtains.
11. Foods and drinks are placed on a rack with the citric acid.
12. Cabinet for poisonous chemicals is open.
13. Students doing the laboratory work are not wearing gloves.
14. The girl is wearing a pair of sandals.

### Possible Answers for Activity 2.2

1. The position of the test tube while heating is towards the students.
2. The student doing the experiment is not wearing gloves.
3. The hair of the student doing the experiment is not tied properly.
4. Observers are too close to the test tube.
5. Copper sulfate should not be heated directly. Wire gauze is necessary.

### Possible Answers for Activity 2.3

1. Long hair, dangling jewelry, and loose or baggy clothing are a hazard in the laboratory. Long hair must be tied back and dangling jewelry and loose or baggy clothing must be secured.
2. Safety goggles and aprons must be worn whenever you work in the lab. Gloves should be worn whenever you use chemicals that cause skin irritations or when you need to handle hot equipment.
3. Keep hands away from your face, eyes, mouth, and body while using chemicals. Wash your hands with soap and water after performing all experiments. Clean (with detergent powder), rinse, and dry all work surfaces and equipment at the end of the experiment.
4. Handle flammable hazardous liquids over a pan to contain spills. Never dispense flammable liquids anywhere near an open flame or source of heat.

### Self-Test 3.1

1. TOXIC
2. FLAMMABLE
3. RADIOACTIVE
4. HARMFUL OR IRRITANT
5. OXIDIZING AGENT
6. CORROSIVE
7. PROPER DISPOSAL
8. HYGIENE
9. ELECTRICAL
10. GLOVES

### Posttest

- |             |             |             |             |              |
|-------------|-------------|-------------|-------------|--------------|
| 1. <b>b</b> | 2. <b>b</b> | 3. <b>a</b> | 4. <b>c</b> | 5. <b>a</b>  |
| 6. <b>c</b> | 7. <b>b</b> | 8. <b>a</b> | 9. <b>a</b> | 10. <b>c</b> |

**-End of Module-**

---

### References:

- Gebelein, Charles G. (2001). *Chemistry and our World*. USA: WCB Wm. C. Brown Publishers
- Lemay, E , Robblee, K, and Beall, H, *Chemistry: Connections to our changing world* : Prentice Hall
- Nolan A. and C. Tucker (1996), *Physical Science*. Heath
- Tillery, Bill W. (1999), *Physical Science*. Singapore: WCB McGraw Hill