



JUN 23 2009

DepED ORDER
No. **66**, s. 2009

ADDENDUM TO DEPED ORDER NO. 56, S. 2009
(Immediate Construction of Water and Hand Washing Facilities in All Schools
for the Prevention of Influenza A (H1N1))

To: DepED ARMM Regional Secretary
Regional Directors
Schools Division/City Superintendents
Regional/Division Physical Facilities Coordinators
Heads, Public Elementary and Secondary Schools
All Others Concerned

1. The following are addenda to DepED Order No. 56, s. 2009:
 - a. The different designs for common hand washing counters including its cost estimates, which may be used by the schools in the implementation of this project are enclosed;
 - b. The designs composed of three types of lavatory counters where school heads can choose the appropriate type for the schools depending on the available budget and school population:
 - Standard Hand Washing Counter (with 10 units of faucets)
 - Type II – Hand Washing Counter (with 5 units of faucets)
 - Type III – Hand Washing Counter (for schools without existing running water)
2. For any assistance and clarifications on the enclosed designs, coordination shall be made with the Physical Facilities and Schools Engineering Division (PFSED) of the Department.
3. Immediate dissemination of and compliance with this Order is directed.

JESLI A. LAPUS
Secretary

Encl.: As stated
Reference: DepED Order: (No. 56, s. 2009)
Allotment: 1—(D.O. 50-97)
To be indicated in the Perpetual Index
under the following subjects:

CHANGE

PUPILS

SCHOOLS

STUDENTS

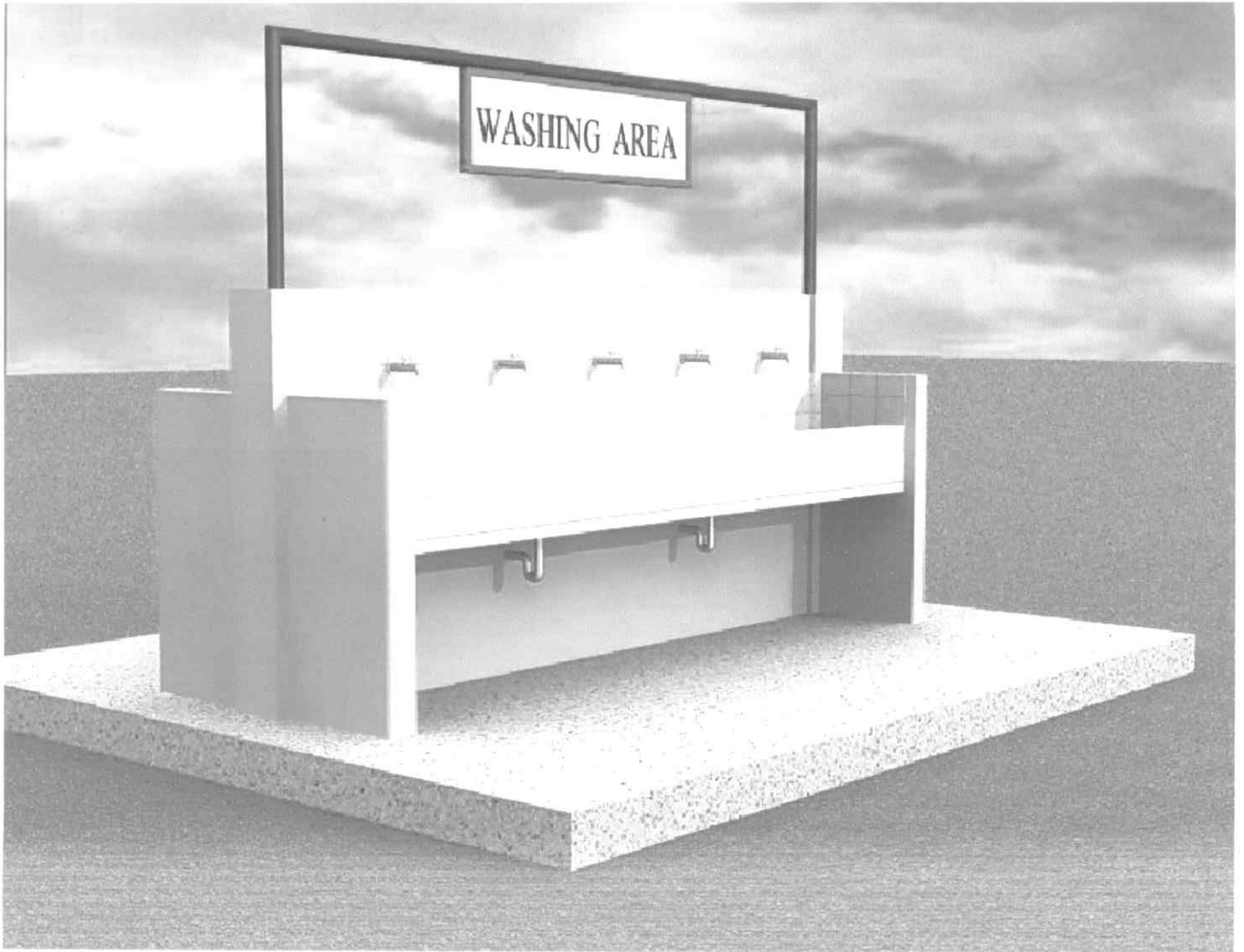

1 PERSPECTIVE
A-1 SCALE: NTS

REPUBLIC OF THE PHILIPPINES



DEPARTMENT OF EDUCATION

PHYSICAL FACILITIES AND SCHOOLS ENGINEERING DIVISION

MERALCO AVENUE, PASIG CITY

PROJECT TITLE:

HAND WASHING COUNTER
DETACHED, (STANDARD)
(10 Unit of Faucet)

h

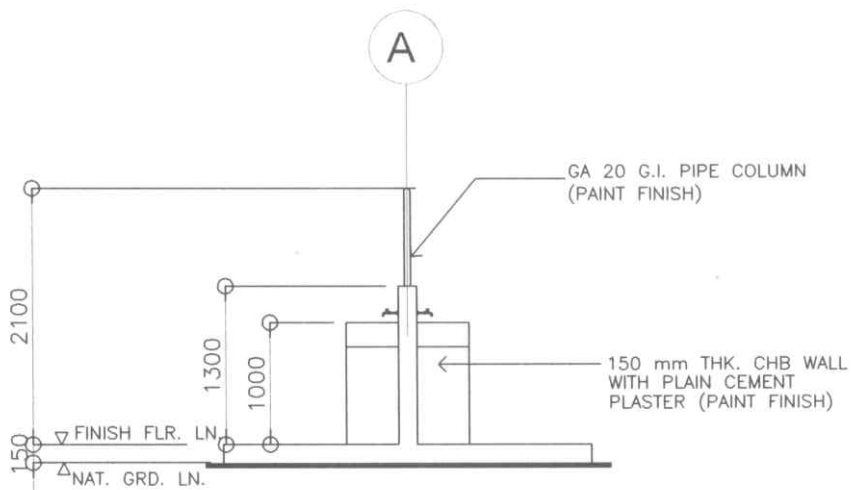

1
A-3

TYPICAL SIDE ELEVATION

SCALE: 1 : 50M

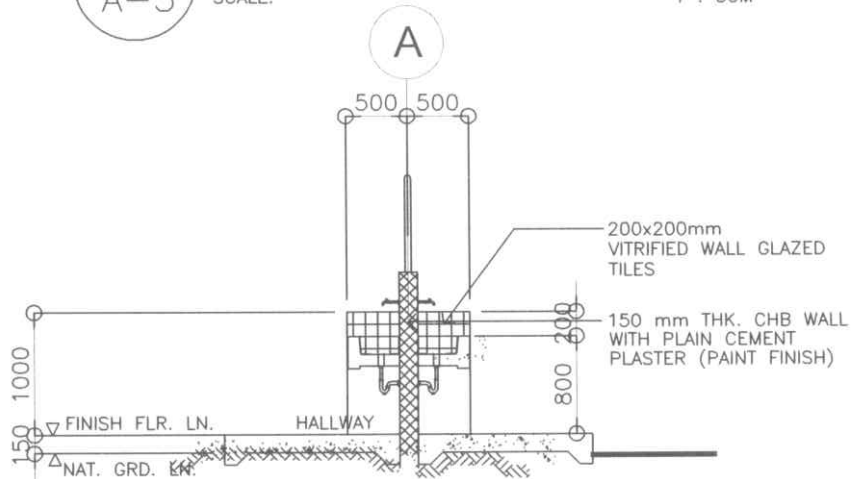

2
A-3

CROSS SECTION

SCALE: 1 : 50M

REPUBLIC OF THE PHILIPPINES



DEPARTMENT OF EDUCATION

PHYSICAL FACILITIES AND SCHOOLS ENGINEERING DIVISION
MERALCO AVENUE, PASIG CITY

PROJECT TITLE:

**HAND WASHING COUNTER
DETACHED, (STANDARD)
(10 Unit of Faucet)**

h

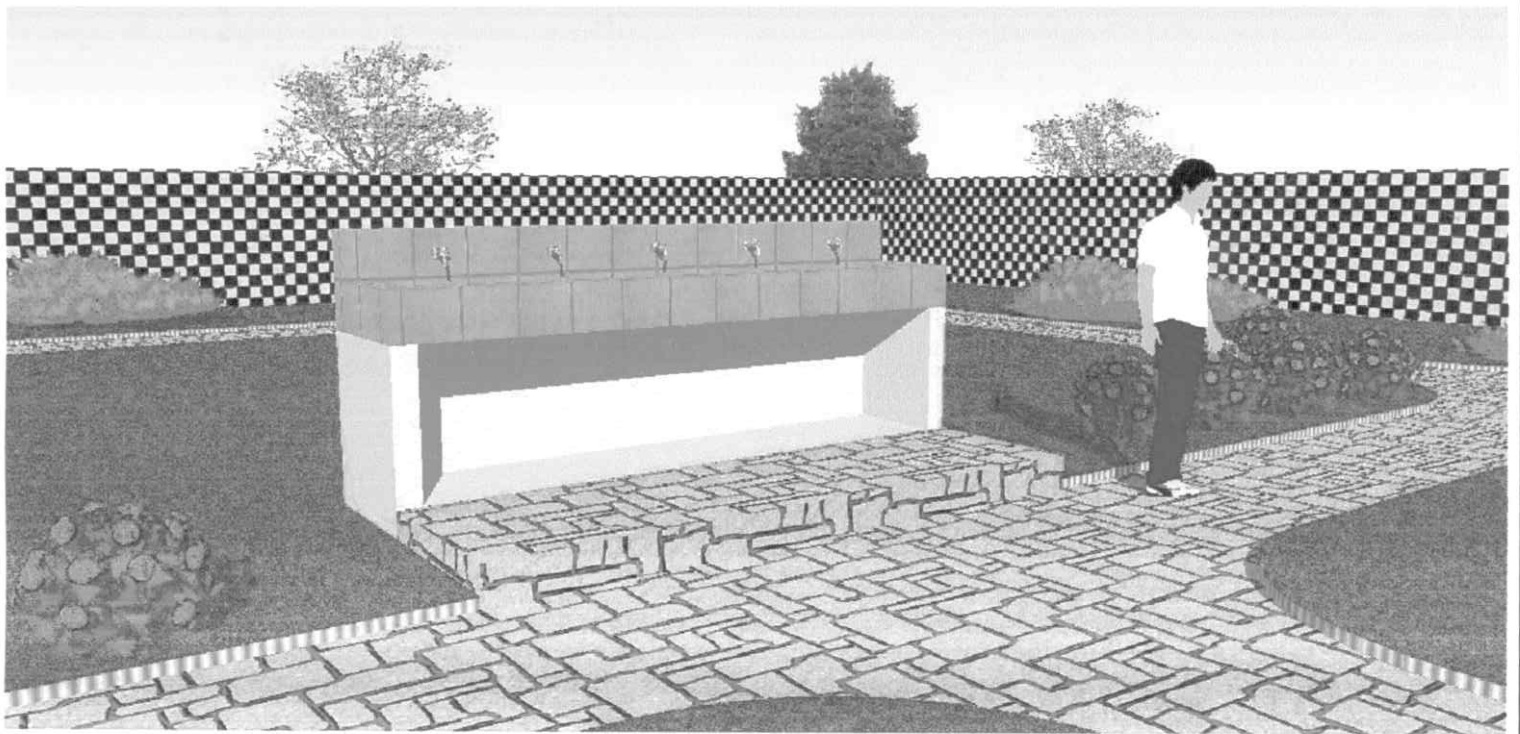

1 PERSPECTIVE
A-1 SCALE: NTS

REPUBLIC OF THE PHILIPPINES



DEPARTMENT OF EDUCATION

PHYSICAL FACILITIES AND SCHOOLS ENGINEERING DIVISION

MERALCO AVENUE, PASIG CITY

PROJECT TITLE:

HAND WASHING COUNTER
DETACHED, (TYPE II, w/ Tiles)
(5 Unit of Faucet)

16

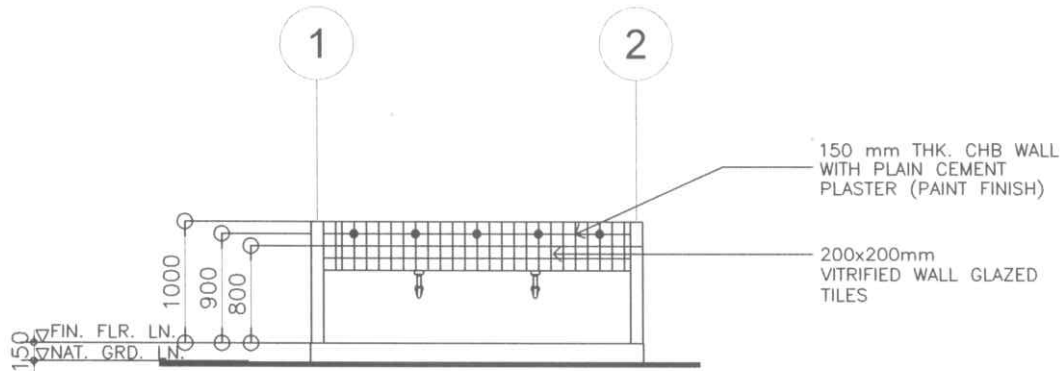

2
FRONT ELEVATION
A-2
 SCALE: 1 : 50M

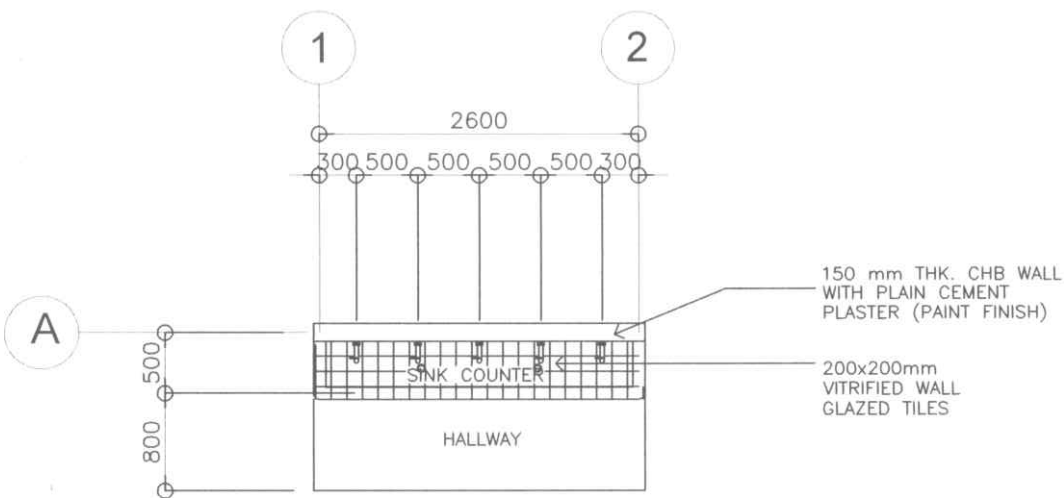

1
FLOOR PLAN
A-2
 SCALE: 1 : 50M

REPUBLIC OF THE PHILIPPINES



DEPARTMENT OF EDUCATION
 PHYSICAL FACILITIES AND SCHOOLS ENGINEERING DIVISION
 MERALCO AVENUE, PASIG CITY

PROJECT TITLE:

**HAND WASHING COUNTER
 DETACHED, (TYPE II, w/ Tiles)
 (5 Unit of Faucet)**



18

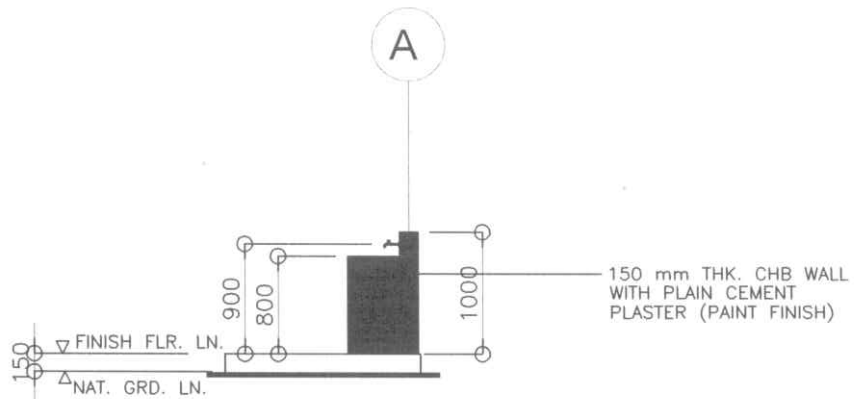

1
A-3

TYPICAL SIDE ELEVATION

SCALE: 1 : 50M

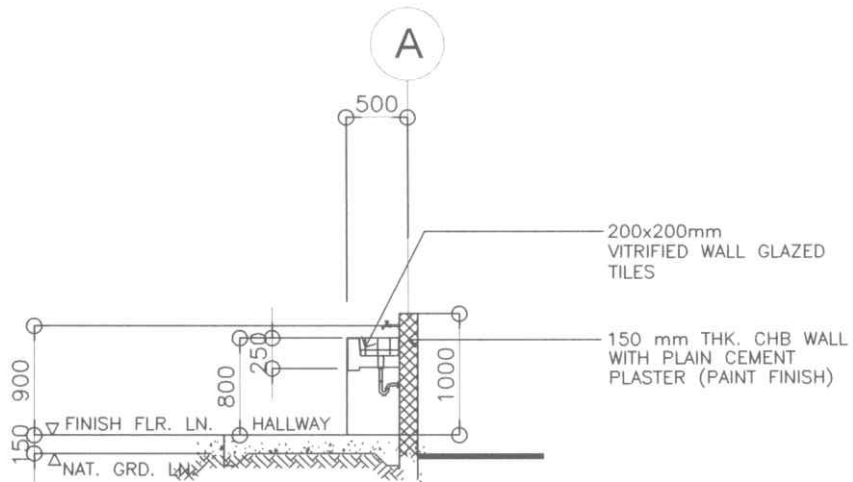

2
A-3

CROSS SECTION

SCALE: 1 : 50M

REPUBLIC OF THE PHILIPPINES



DEPARTMENT OF EDUCATION

PHYSICAL FACILITIES AND SCHOOLS ENGINEERING DIVISION

MERALCO AVENUE, PASIG CITY

PROJECT TITLE:

**HAND WASHING COUNTER
DETACHED, (TYPE II, w/ Tiles)
(5 Unit of Faucet)**



1

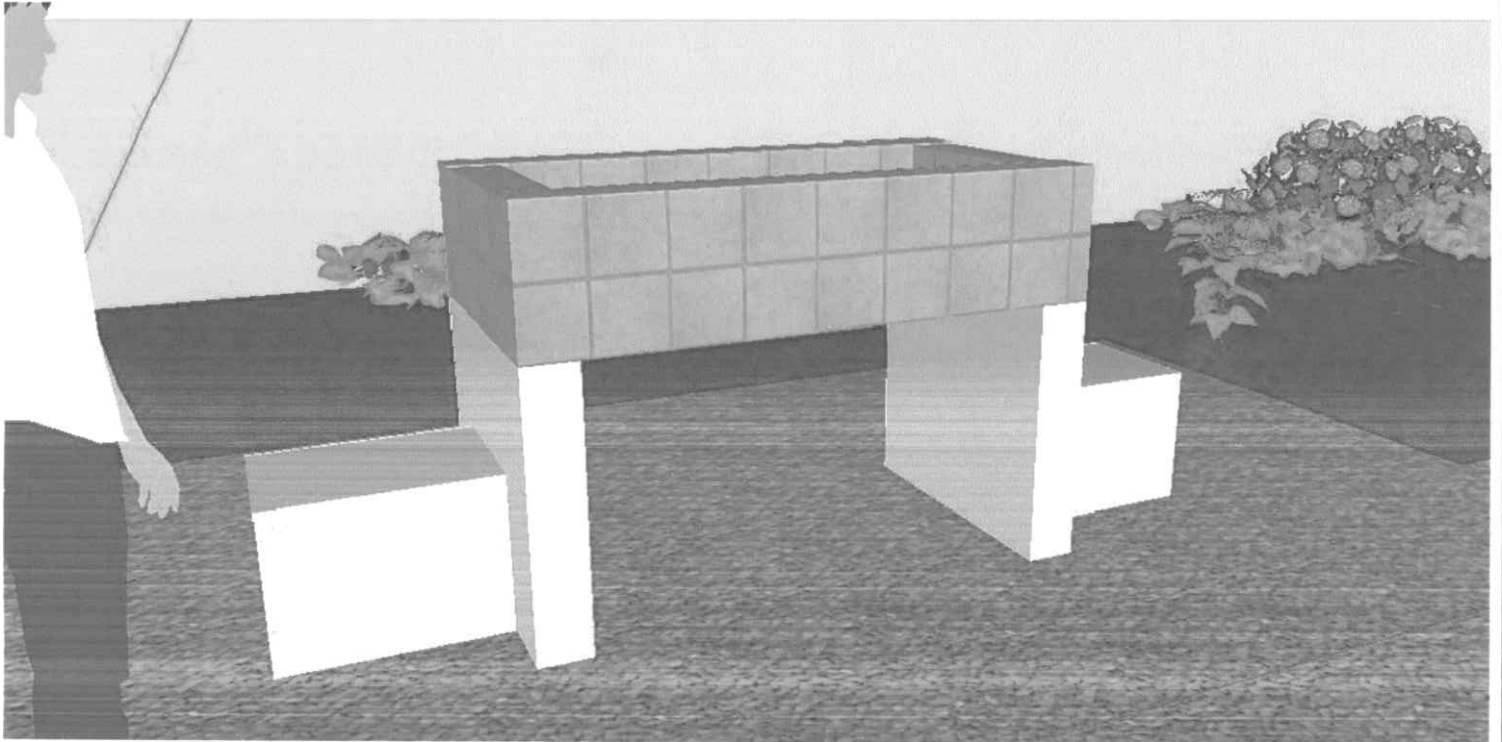

1 PERSPECTIVE
A-1 SCALE: NTS

REPUBLIC OF THE PHILIPPINES



DEPARTMENT OF EDUCATION

PHYSICAL FACILITIES AND SCHOOLS ENGINEERING DIVISION
MERALCO AVENUE, PASIG CITY

PROJECT TITLE:

HAND WASHING COUNTER
DETACHED, (TYPE III)
(Capacity of four students)

16

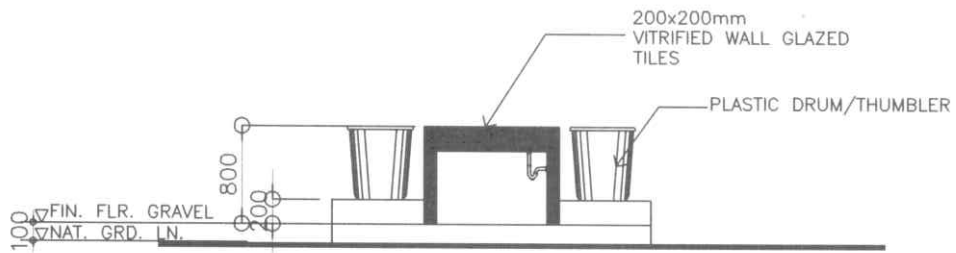

2 FRONT ELEVATION
A-2 SCALE: 1 : 50M

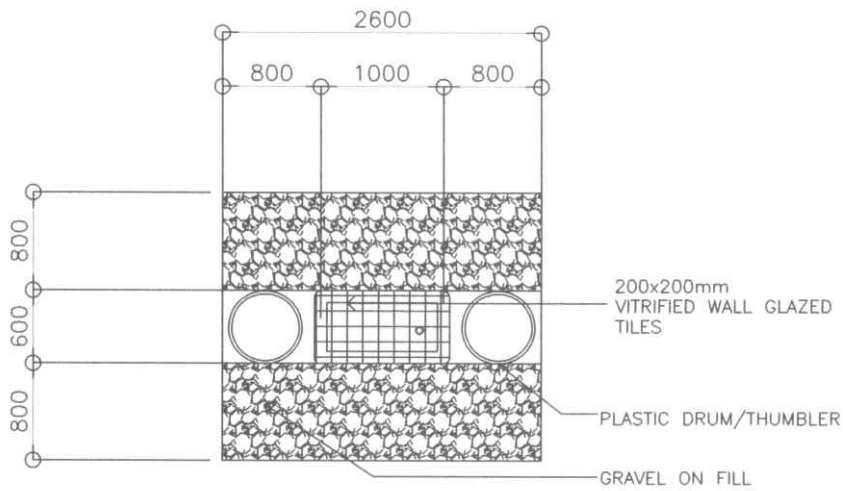

1 FLOOR PLAN
A-2 SCALE: 1 : 50M

REPUBLIC OF THE PHILIPPINES



DEPARTMENT OF EDUCATION

PHYSICAL FACILITIES AND SCHOOLS ENGINEERING DIVISION

MERALCO AVENUE, PASIG CITY

PROJECT TITLE:

HAND WASHING COUNTER
DETACHED, (TYPE III)
(Capacity of four students)



A

Enclosure No. 4 to DepED Order No. 66, s. 2009



Republic of the Philippines
DEPARTMENT OF EDUCATION
PHYSICAL FACILITIES AND SCHOOLS ENGINEERING DIVISION
DepED Complex, Meralco Avenue, Pasig City



Regional Costing of Hand Washing Facility Counters

REGION	TYPE I (for 10-unit of faucet)	TYPE II (for 5-unit of faucet)	TYPE III (for schools without running water)
NCR	43,000.00	21,000.00	13,000.00
R-I	41,000.00	19,000.00	11,000.00
R-II	43,000.00	21,000.00	13,000.00
R-III	39,000.00	19,000.00	11,000.00
R-IV A	45,000.00	22,000.00	14,000.00
R-IV B	43,000.00	20,000.00	12,000.00
R-V	40,000.00	19,000.00	11,000.00
R-VI	42,000.00	20,000.00	12,000.00
R-VII	45,000.00	23,000.00	15,000.00
R-VIII	50,000.00	23,000.00	15,000.00
R-IX	44,000.00	21,000.00	13,000.00
R-X	45,000.00	22,000.00	14,000.00
R-XI	43,000.00	21,000.00	13,000.00
R-XII	42,000.00	20,000.00	12,000.00
CARAGA	46,000.00	22,000.00	14,000.00
ARMM	42,000.00	20,000.00	12,000.00
CAR	50,000.00	24,000.00	16,000.00

NOTE: Costing excludes handling/hauling costs and cost of connection to main water source.

Hand Washing Facility Counters

NOTE: Costing was based on normal site conditions.

HAND WASHING FACILITY COUNTERS DETAILED ESTIMATES

			TYPE I (per 10- Unit of Faucet)	TYPE II (per 5- Unit of Faucet)	TYPE III (for schools without running water)
I.D. NO	DESCRIPTION	UNIT	QUANTITY	QUANTITY	QUANTITY
	A GENERAL REQUIREMENTS				
	Mobilization/Temporary Structures, Utilities and Services/Demobilization / Standard Billboard	lot	1.00	1.00	1.00
1.00	B Earthworks				
1.01	Clearing and Grubbing	sq.m	10.80	3.38	1.56
1.03	Backfilling and Compaction	cu.m	1.08	0.34	0.57
1.04	Gravel Bedding G-1	cu.m	1.08	0.34	0.57
2.00	C Concreting Works				
	Counter	cu.m	0.43	0.20	0.14
2.01	Portland Cement	bag	4.00	2.00	2.00
2.02	Crushed Gravel 3/4"	cu.m	0.50	0.25	0.25
2.03	Washed Sand	cu.m	0.25	0.25	0.25
	Column	cu.m	0.06		
2.01	Portland Cement	bag	1.00		
2.02	Crushed Gravel 3/4"	cu.m	0.25		
2.03	Washed Sand	cu.m	0.25		
	Slab on Grade	cu.m	1.62	0.51	0.16
2.01	Portland Cement	bag	15.00	5.00	2.00
2.05	Crushed Gravel 1"	cu.m	1.75	0.75	0.25
2.03	Washed Sand	cu.m	1.00	0.50	0.25
3.00	D Rebar Works				
	Counter				
3.01	Deformed Round Bars, Grade 40	kg	12.67	6.34	3.96
3.02	G.I. Tie Wire	kg	1.00	1.00	1.00
	Column				
3.01	Deformed Round Bars, Grade 40	kg	16.02		
3.02	G.I. Tie Wire	kg	1.00		
	Slab on Grade				
3.01	Deformed Round Bars, Grade 40	kg	20.91	7.72	3.72
3.02	G.I. Tie Wire	kg	1.00	1.00	1.00
4.00	E Formworks				
	Column	sq.m	1.56		
4.01	Coco Lumber	bd.ft	8.10		
4.02	Plywood Ordinary, 1/4" x 4' x 8'	pc	1.00		
4.04	CWN, Assorted	kg	1.00		
5.00	F Masonry Works				
	Masonry Wall	sq.m	5.64	3.40	1.52
5.05	CHB 6" thk	pc	71.00	43.00	19.00
5.02	Portland Cement	bag	3.00	2.00	1.00
5.03	Washed Sand	cu.m	1.00	1.00	1.00
5.06	10mm x 6m RSB	kg	8.00	5.00	3.00
5.07	G.I. Tie Wire	kg	1.00	1.00	1.00

Handwritten initials and a signature.

HAND WASHING FACILITY COUNTERS DETAILED ESTIMATES

I.D. NO	DESCRIPTION	UNIT	TYPE I (per 10- Unit of Faucet)	TYPE II (per 5- Unit of Faucet)	TYPE III (for schools without running water)
			QUANTITY	QUANTITY	QUANTITY
	Plastering	sq.m	11.28	6.80	3.04
5.02	Portland Cement	bag	4.00	3.00	2.00
5.03	Washed Sand	cu.m	1.00	1.00	1.00
7.00	H Steel Works				
8.11	Plain G.I. Sheet Ga.26, 3' x 8'	pc	1.00		
7.45	G.I. Pipe 2"Ø Sch.40	pc	1.00		
7.46	Welding Rod	kg	0.50		
13.12	Primer, Zinc Chromate	gal	0.25		
11.00	L Plumbing Works				
11.59	Faucet, Plain Bibb, Brass 1/2"Ø	pc	10.00	5.00	
11.44	Gate Valve, 1/2"Ø	pc	1.00	1.00	
11.06	G.I. Pipe 1/2"Ø Sch.40	pc	3.00	3.00	
11.21	G.I. Elbow 90o x 1/2"Ø	pc	10.00	5.00	
12.30	uPVC P-Trap 2"	pc	4.00	2.00	1.00
12.07	uPVC Sanitary Pipe 2"Ø	pc	8.00	4.00	2.00
12.22	uPVC Wye 2" x 2"	pc	2.00	2.00	1.00
	PVC Cleanout	pc	2.00	2.00	1.00
11.15	G.I. Tee, 1/2"Ø	pc	10.00	5.00	
11.65	S.S.Floor Drain 4' x 4"	pc	4.00	2.00	1.00
11.66	Teflon Tape	roll	2.00	2.00	1.00
13.00	N Painting Works				
	Concrete surfaces	sq.m	11.28	6.80	3.04
13.18	Neutralizer	gal	0.25	0.25	0.25
13.01	Latex, Flat	gal	0.25	0.25	0.25
13.14	Masonry Putty	gal	0.25	0.25	0.25
13.02	Latex, Semi Gloss	gal	0.25	0.25	0.25
14.00	O Tile Works				
	Sink Counter	sq.m	4.56	2.08	0.92
14.04	Glazed Wall Tiles 20cm x 20cm	pc	118.00	54.00	24.00
14.16	Tile Adhesive 25 kg/bag	bag	1.00	1.00	1.00
14.15	Tile Grout 5 kg/bag	bag	1.00	1.00	1.00
	Tumbler and Dipper				
	Tumbler	pc			2.00
	Dipper	pc			2.00

Handwritten marks: a vertical line and a squiggle.

Enclosure No. 5 to DepED Order No. 66, s. 2009

PROJECT : **PROPOSED TIPPY TAP WASH STATION**
DESIGN: **ESSENTIAL HEALTH CARE PACKAGE DESIGN**
SUBJECT: **BILL OF MATERIALS & COST ESTIMATES**

ITEMS	PARTICULAR UNIT	COST PER UNIT	TOTAL COST
1.) 2"x 2" x 8' WOOD	12 bdf.	P 59	P 708.00
2.) 1/2" FINISHING NAILS	1/2kilo	P 68/kilo	P 34.00
3.) 1 1/2" FINISHING NAILS	1 kilo	P 68/kilo	P 68.00
4.) PLAIN ORDINARY G.I SHEET (gauge 26)	1/2 pc.	P 220.00/pc.	P 110.00
5.) 3mm NYLON ROPE	8m	P 1.65/m	P 13.20
6.) BENT NAILS/ HOOK SCREW	8pcs.	0	P 0.00
7.) PLASTIC CONTAINER	1pc.	P 50	P 50.00
8.) USED STOCKINGS	4 pairs	0	P 0.00
9.) USED EMPTY BOTTLES	8pcs.	0	<u>P 0.00</u>
TOTAL			P 983.20

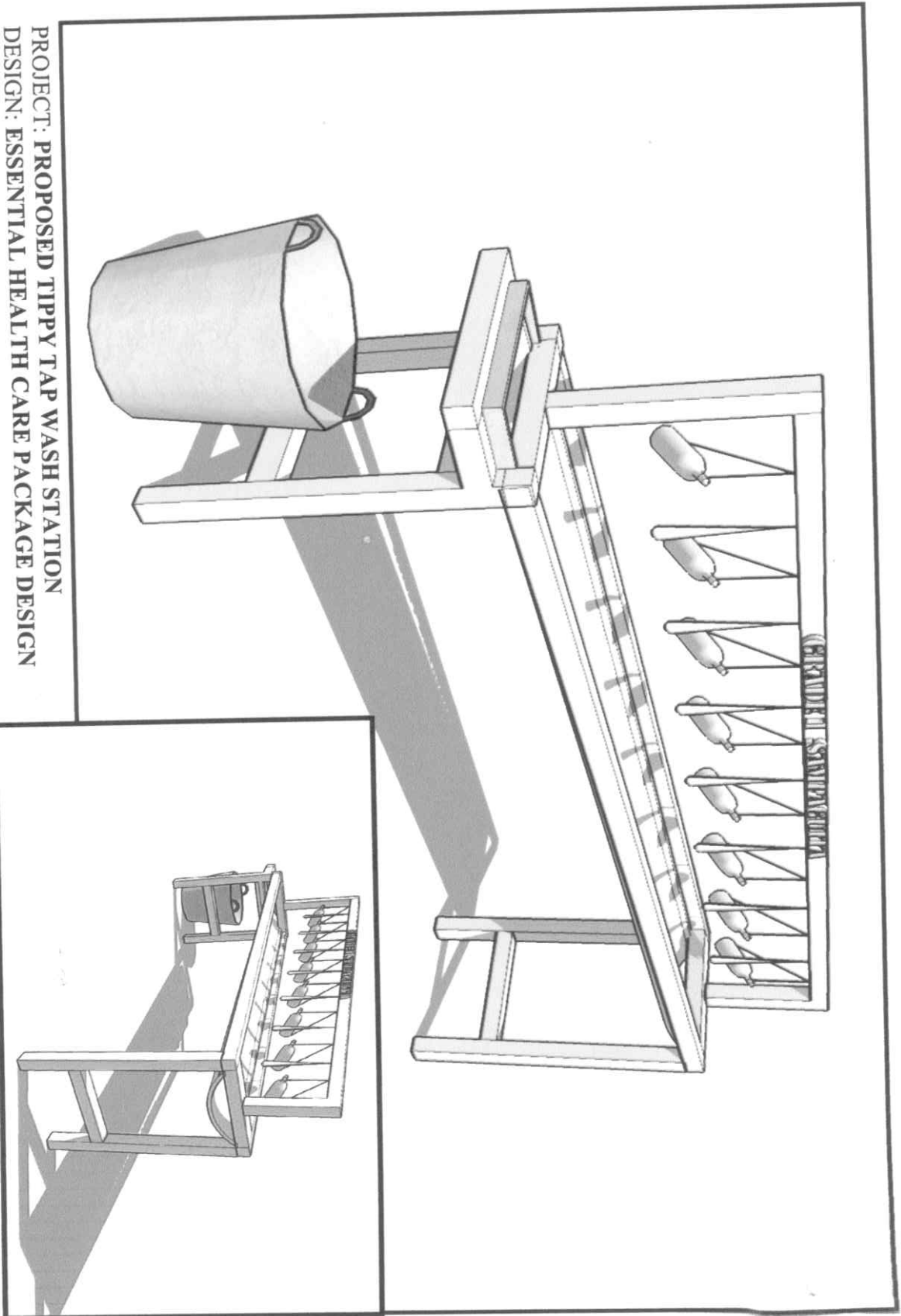

PROJECT: PROPOSED TIPPY TAP WASH STATION
DESIGN: ESSENTIAL HEALTH CARE PACKAGE DESIGN

PERSPECTIVE

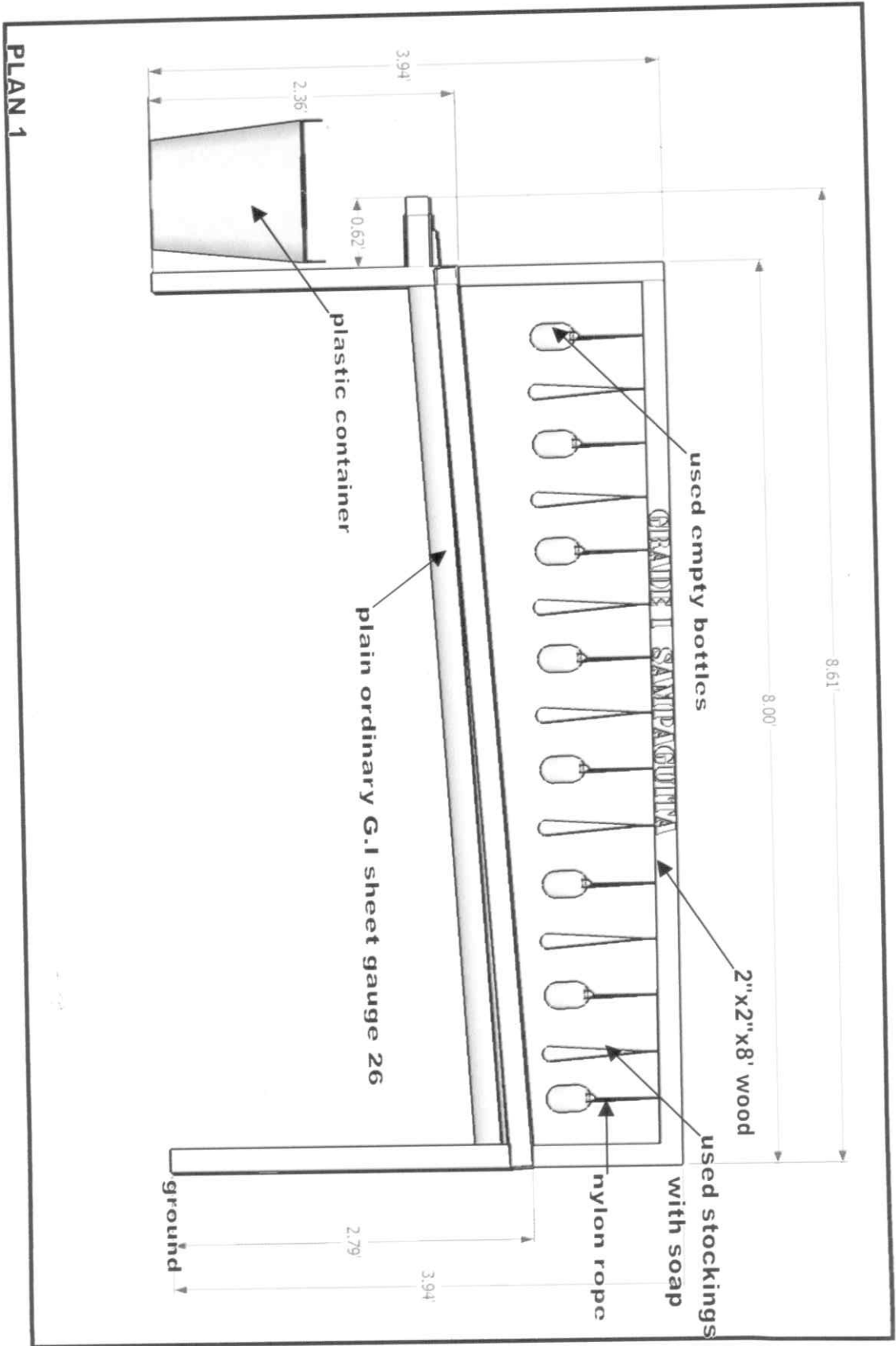

Ab

DETAILS

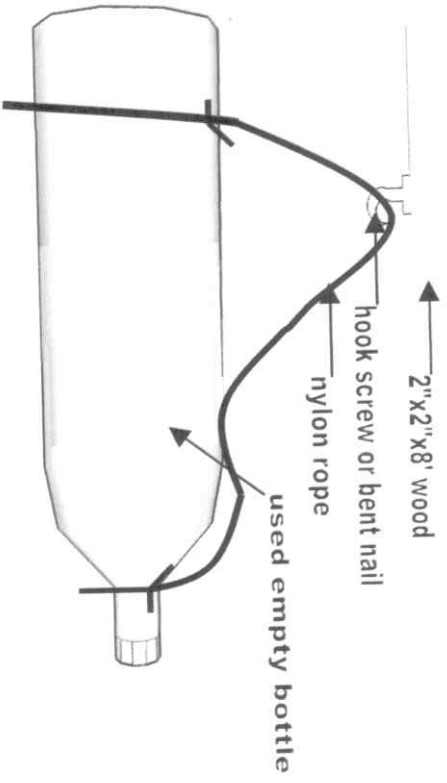

1. Fix a nylon rope to the bottle and remove the label.

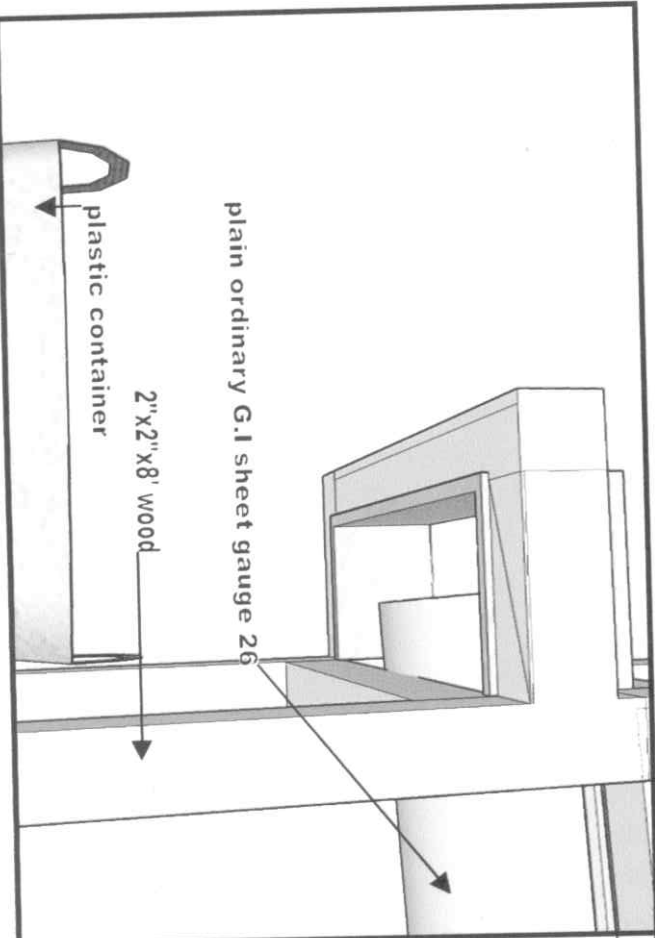

2. Make a hole in the cap of each empty water bottle.

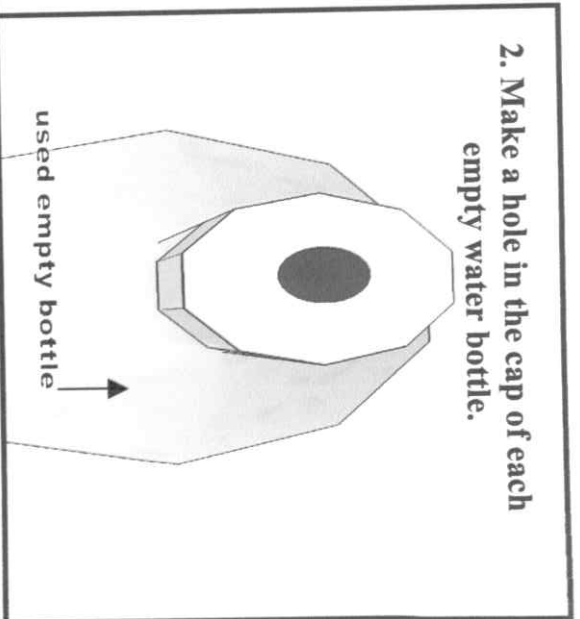

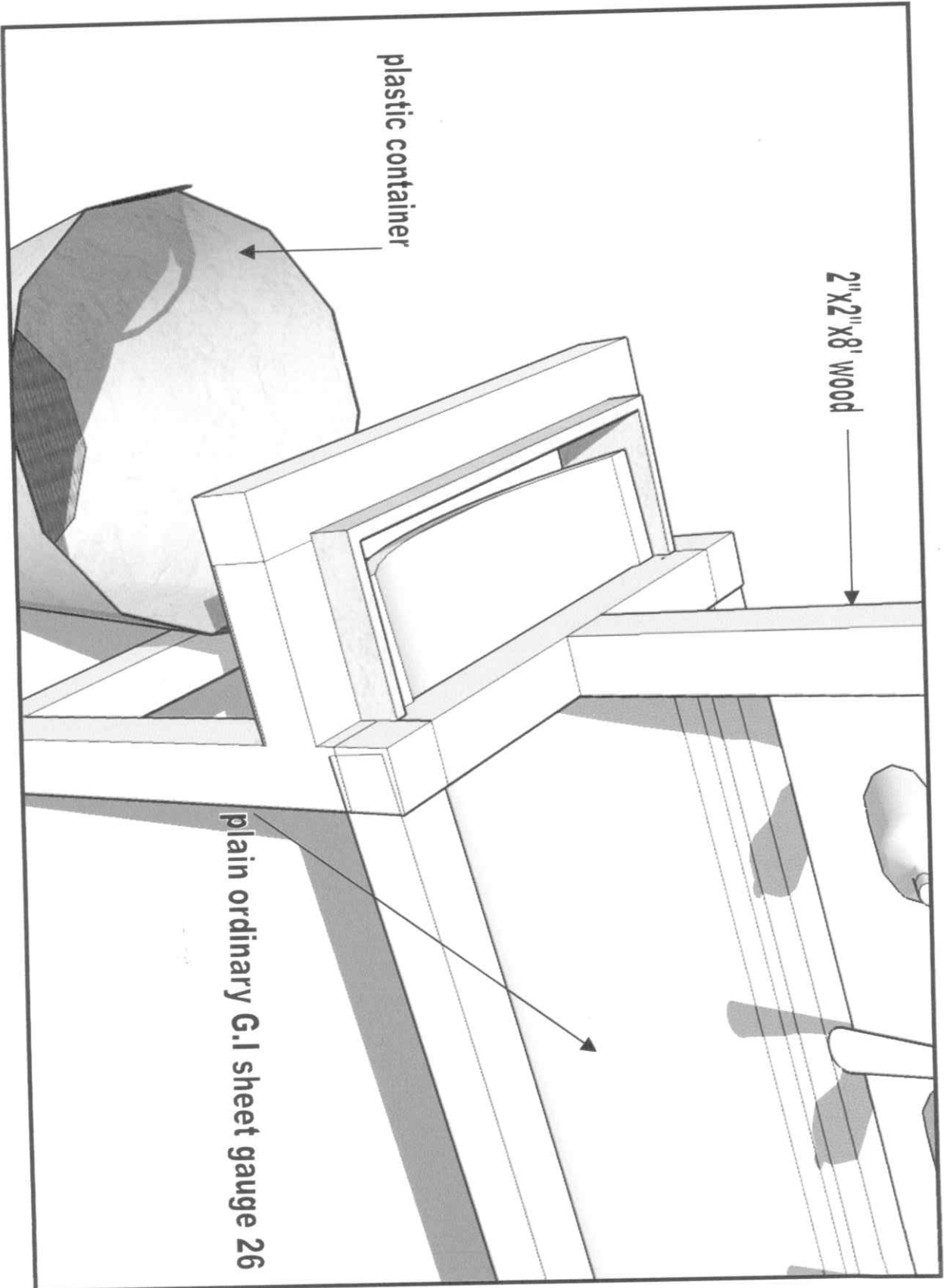

plastic container

2" x 2" x 8' wood

plain ordinary G.I sheet gauge 26

8

PROJECT : **PROPOSED GROUP HAND WASHING FACILITY**
 DESIGN: **ESSENTIAL HEALTH CARE PACKAGE DESIGN**
 SUBJECT: **BILL OF MATERIALS & COST ESTIMATES**

ITEM	PARTICULAR UNIT	COST PER UNIT	TOTAL COST
1.) 2"x 2" x 8' WOOD	15 bdf.	P 59	P 885.00
2.) 1/2" FINISHING NAILS	1/2kilo	P 68/kilo	P 34.00
3.) 1 1/2" FINISHING NAILS	1 kilo	P 68/kilo	P 68.00
4.) PLAIN ORDINARY G.I SHEET (gauge 26)	1/2 pc.	P 220.00/pc	P 110.00
5.) PLASTIC CONTAINER	1pc.	P 50	P 50.00
6.) 1/2" Ø PVC PIPE	2pc.	P 70/ 8 ft'	P 140.00
7.) 1/2" Ø PLAIN PVC BALL VALVE	1 pc.	P 130.00	P 130.00
8.) 1/2" Ø G.I ELBOW	1 pc.	P 20.00	P 20.00
9.) 1/2" Ø PVC CUP	1pc.	P 10.00	P 10.00
10.) 1/2" Ø PLAIN PVC PIPE ELBOW	1pc.	P 23.00	P 23.00
11.) 1/2" Ø PVC MALE ADAPTOR	1pc.	P 13.00	P 13.00
TOTAL			P 1,483.00

A

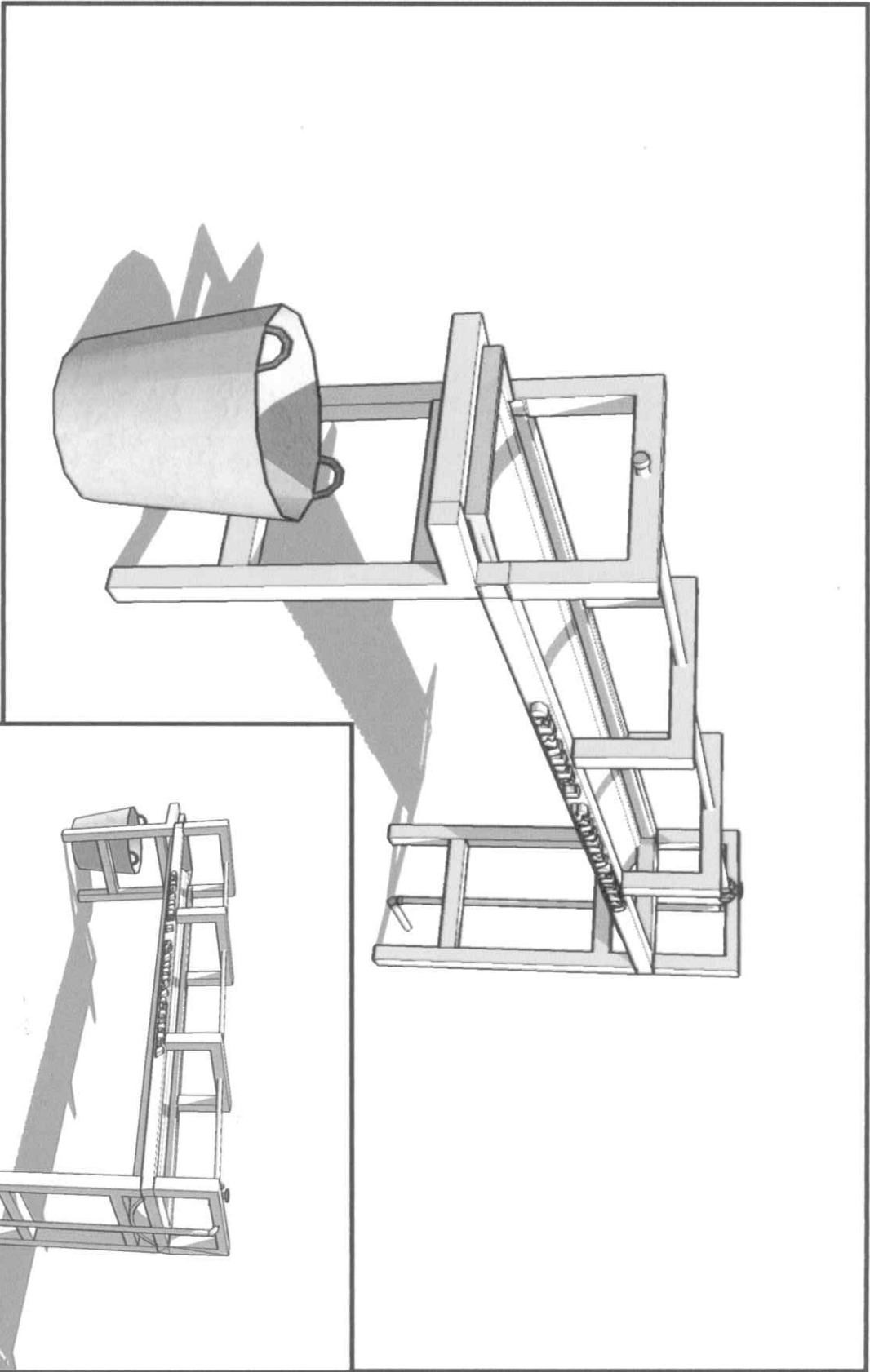

PROJECT: PROPOSED GROUP HAND WASHING FACILITY
DESIGN: ESSENTIAL HEALTH CARE PACKAGE DESIGN

A

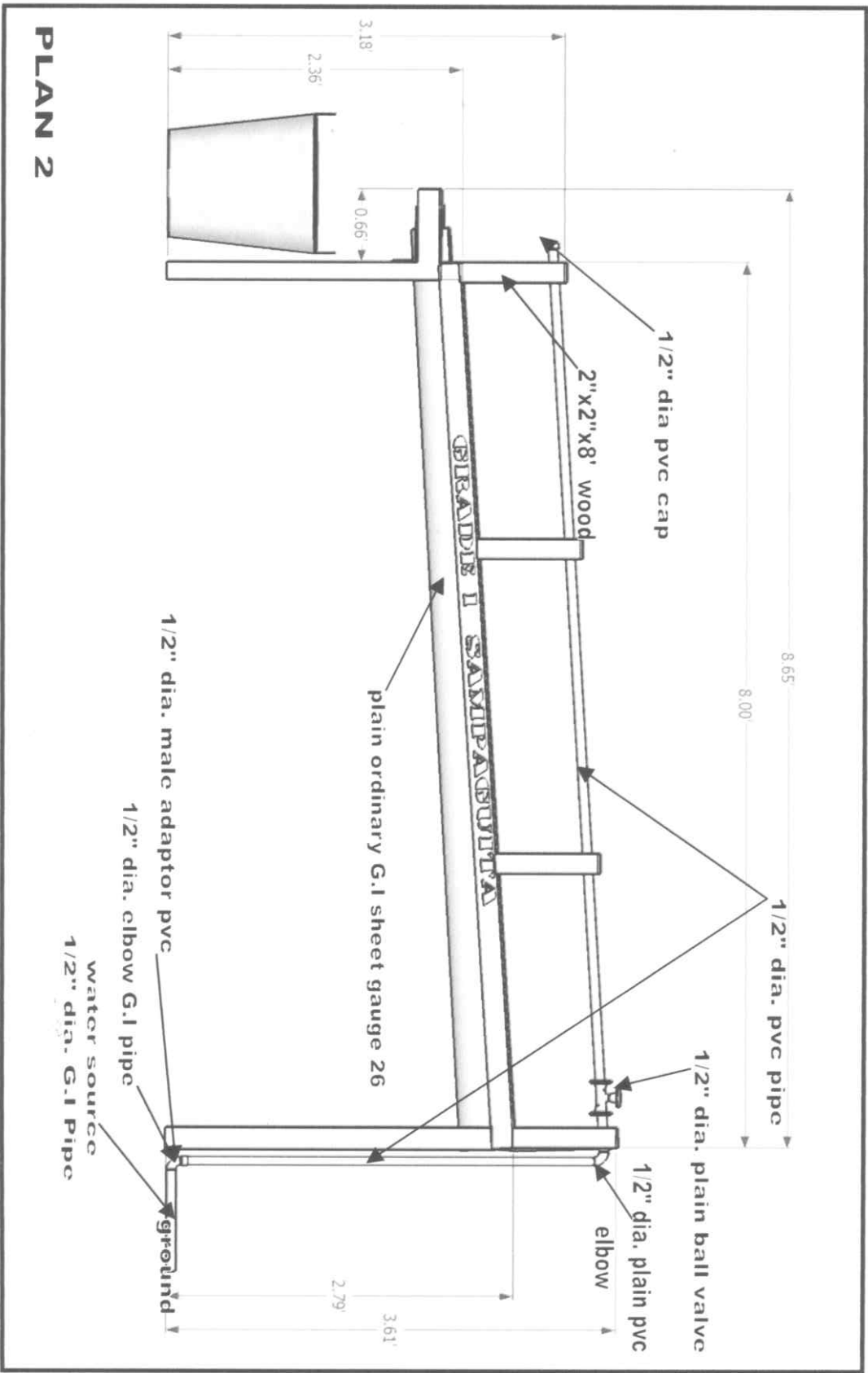

PROJECT: PROPOSED GROUP HAND WASHING FACILITY
 DESIGN: ESSENTIAL HEALTH CARE PACKAGE DESIGN

A

DETAILS

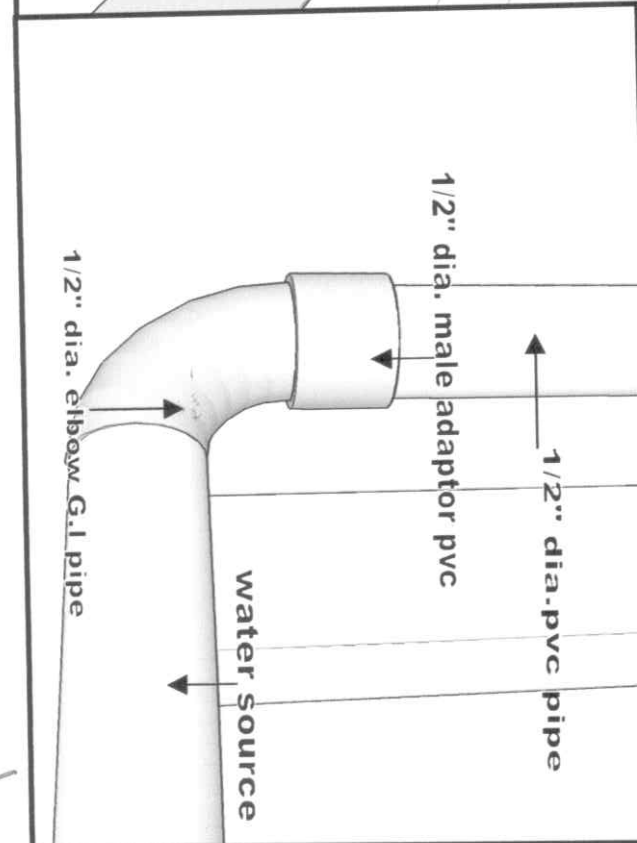
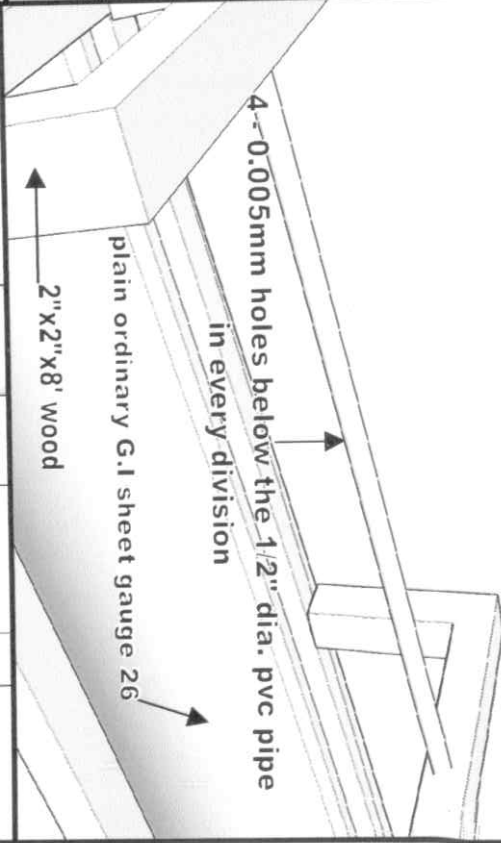
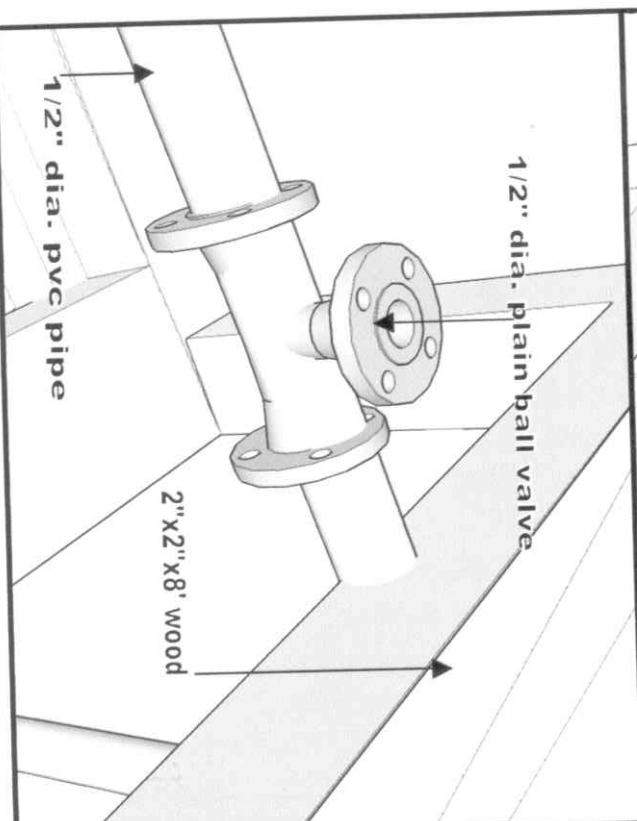
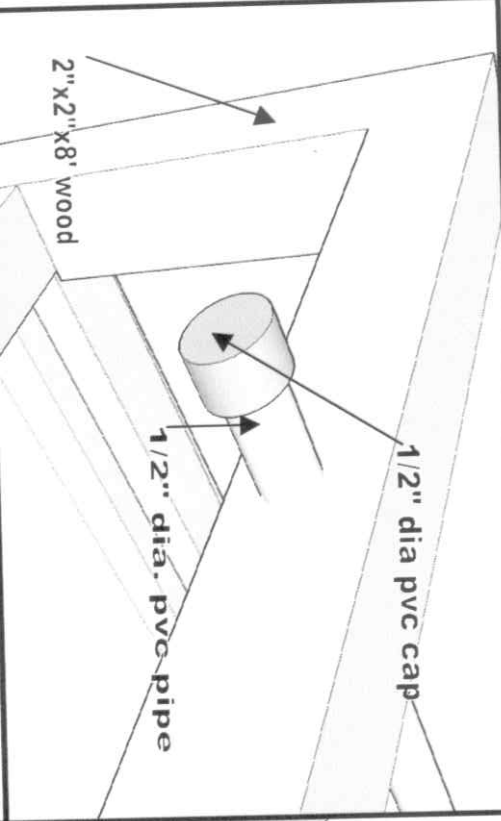

A

DETAILS

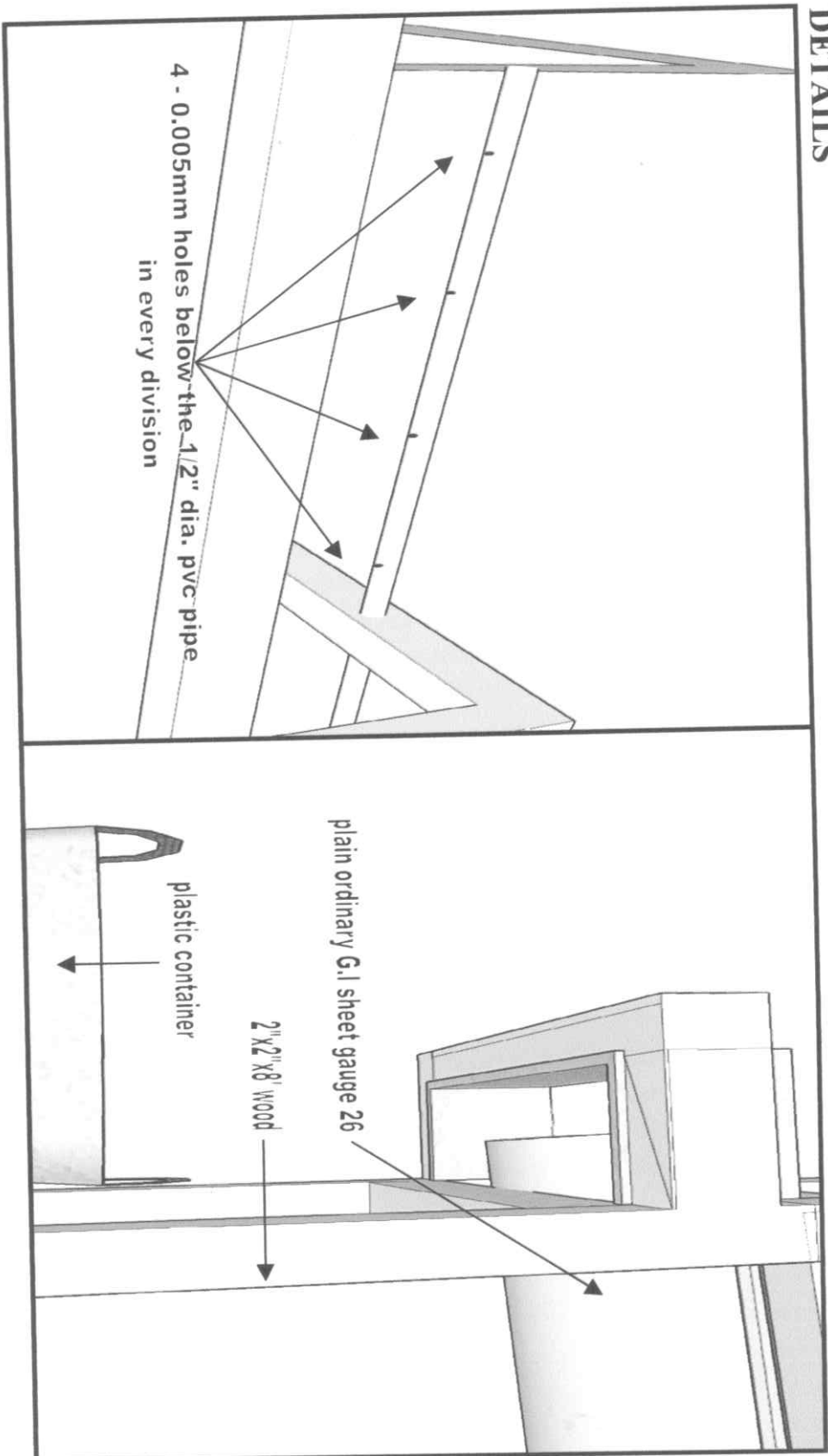

A

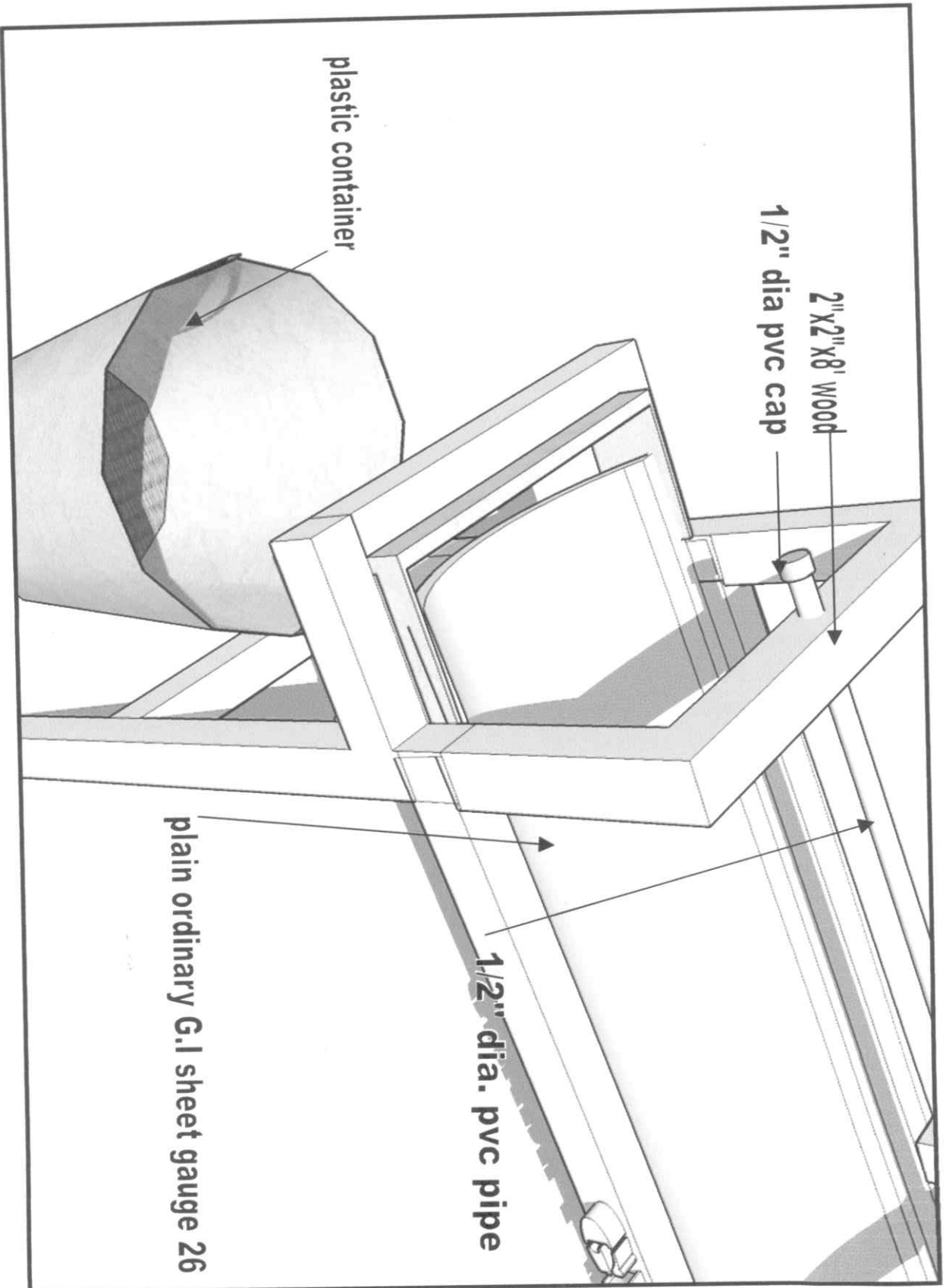

A

TYPE III:

HAND WASHING COUNTER ALTERNATIVE DESIGNS

(For schools without existing running water)

Designed by: ESSENTIAL HEALTH CARE PACKAGE

- 1. Tippy Tap Wash Station**
 - 2. Group Hand Washing Facility**
- In order to reduce/ minimize costs, a school may consider alternatives for the materials indicated in the proposal:

MATERIAL	ALTERNATIVE
Commercial Wood	Bamboo, branches of trees
GI Sheet	Recycled plain sheet, gutter
Plastic Container (new)	used plastic containers, old paint cans, old metal bins

- The facility may be located along the corridors or at the side or at the back of building/ classroom or any vacant space outside the classroom, preferably where there is a roof or extended roofing.